



## **BEST MANAGEMENT PRACTICES**

**For Activities Taking Place in and  
around Water Habitats in  
Kahnawà:ke and Tioweró:ton**



## Preface

Kahnawà:ke is bordered by the beautiful St. Lawrence River and is fortunate to also host an extensive network of tributaries, creeks, and wetlands. Tioweró:ton also hosts a variety of water habitats including wetlands, creeks and lakes.

Our creeks, lakes, rivers and wetlands provide important habitat for a wide variety of plants, reptiles, amphibians, fish, insects, birds, and mammals. The waters also perform important drainage and purification functions for the health of the community as well as providing recreational opportunities.

We value our water habitats and acknowledge our role and responsibility to keep them healthy. The water habitats must be maintained in a healthy state in order to continue providing valuable habitat, recreational opportunities, health benefits, and effective drainage and flood protection for our community. These Best Management Practices serve as a guide for anyone undertaking maintenance and development activities in and around the water habitats of Kahnawà:ke and Tioweró:ton, including:

- MCK planners and workers
- Individual community members
- Local businesses
- Non-local agencies (eg. Ministère des Transports du Québec, etc.)
- Contractors

The ultimate goal of this handbook is to encourage and guide the implementation of appropriate environmental protection, mitigation, and restoration measures in all activities taking place in or near water habitats in our territories.

The contents of this handbook were drawn from many knowledgeable sources and jurisdictions with extensive experience protecting water habitats. All sources are listed in the reference section at the end of this handbook.

# Table of Contents

<b>PREFACE</b> .....	<b>2</b>
<b>PURPOSE</b> .....	<b>5</b>
<b>OVERVIEW</b> .....	<b>6</b>
<b>GLOSSARY OF TERMS</b> .....	<b>7</b>
<b>PART 1: WATER HABITATS IN KAHNAWÀ:KE AND TIOWERÓ:TON</b> .....	<b>8</b>
WETLANDS .....	8
RIVERS AND CREEKS.....	11
SHORELINES.....	13
ENVIRONMENTALLY SENSITIVE HABITATS IN KAHNAWÀ:KE .....	16
ENVIRONMENTALLY SENSITIVE HABITATS IN TIOWERÓ:TON .....	20
<b>PART 2: POTENTIAL IMPACTS OF ACTIVITIES IN OR NEAR WATER</b> .....	<b>22</b>
CREEK, DITCH AND SHORELINE MAINTENANCE .....	23
CREEK CROSSINGS .....	24
EXCAVATION AND RELOCATION OF SOIL.....	24
ASPHALT RESURFACING .....	25
LANDFILLING.....	25
<b>PART 3: BMPS FOR ALL STAGES OF A PROJECT</b> .....	<b>26</b>
PROJECT PLANNING AND SCHEDULING .....	26
PROJECT DESIGN.....	29
EDUCATION AND TRAINING .....	30
WORK SITE MANAGEMENT.....	31
VEHICLE AND EQUIPMENT MANAGEMENT.....	36
SPILL PREVENTION AND CONTROL .....	37
VEGETATION MANAGEMENT .....	37
FILL MANAGEMENT .....	40
EROSION CONTROL.....	41
<i>Manage Construction Activities</i> .....	42
<i>Stabilize the Soil Using Mulching and Mats</i> .....	42
SEDIMENT CONTROL.....	44
<i>Silt Fence</i> .....	44
<i>Silt Curtain</i> .....	45
<i>Straw Bale Barriers</i> .....	49
<i>Rock Check Dams</i> .....	50
<i>Mud mat</i> .....	52
SITE RESTORATION .....	52
<i>Plant Rescue</i> .....	52
<i>Dormant Cuttings and Live Staking</i> .....	52
<i>Brush Mats</i> .....	56
<i>Grass Rolls</i> .....	58
BEAVER CONTROL AND DAM REMOVAL.....	61
NEXT STEPS .....	62
<b>REFERENCES</b> .....	<b>63</b>
<b>APPENDIX A: NATIVE PLANT SPECIES FOR RE-VEGETATION OF CREEK BANKS AND SHORELINES IN KAHNAWÀ:KE</b> .....	<b>65</b>
<b>APPENDIX B: INVASIVE PLANT SPECIES</b> .....	<b>66</b>

<b>APPENDIX C: SUPPLIERS OF MITIGATION PRODUCTS .....</b>	<b>68</b>
<b>APPENDIX D: IMPORTANT CONTACT NUMBERS .....</b>	<b>69</b>
<b>APPENDIX E: LANDFILL POLICY AND PROCEDURES FOR CLEAN SOIL (2013).....</b>	<b>70</b>

## List of Figures

- Figure 1: Kahnawà:ke Wetland Inventory Map
- Figure 2: Wetland Habitat in Kahnawà:ke (photo)
- Figure 3: Heavy Machinery in Creek Habitat in Kahnawà:ke (photo)
- Figure 4: Healthy Creek Habitat Flowing into the Little Suzanne River (photo)
- Figure 5: Landfilling on Shoreline Habitat in Kahnawà:ke (photo)
- Figure 6: Healthy Creek Habitat Near McGregor Farm (photo)
- Figure 7: Map of Johnson’s Point / Big Fence Area
- Figure 8: Map of the North Wall Area
- Figure 9: Map of Tekakwitha Island, Recreational Bay and Bike Paths
- Figure 10: Creek Habitat in Tioweró:ton Disturbed by All Terrain Vehicles (photo)
- Figure 11: Creek Crossing in Tioweró:ton Showing Erosion Problems (photo)
- Figure 12: Components of the Water Ecosystem that are Sensitive to Disturbances
- Figure 13: Characteristics of a Well-Designed Creek Crossing
- Figure 14: Building Temporary Creek Crossings for Access to Project Sites
- Figure 15: Constructing a Designated Vehicle and Equipment Wash Area
- Figure 16: Preventing Spills and Planning for Emergencies
- Figure 17: Impermeable Membrane Under and Over Excavated Fill
- Figure 18: Mulching Slopes with Loose Straw to Reduce Erosion (photo)
- Figure 19: Using Coir Mats to Protect Exposed Areas Prior to Re-vegetation (photo)
- Figure 20: Silt Fence Installation
- Figure 21: Silt Curtain Installation
- Figure 22: Straw Bale Barrier Installed Across a Ditch
- Figure 23: Typical Rock Check Dam Installation Details
- Figure 24: Harvesting Dormant Cuttings for Re-vegetation
- Figure 25: Planting Dormant Cuttings Using Live Staking
- Figure 26: Brush Mat Re-Vegetation Technique (photo)
- Figure 27: Brush Mat Installation Instructions
- Figure 28: Re-vegetating a Creek Bank with Native Grasses
- Figure 29: Grass Roll Installation Instructions

## List of Tables

- Table 1: Activities Near Water and their Potential Environmental Impacts
- Table 2: Scheduling Work in and Around Water Habitats in Kahnawà:ke
- Table 3: Scheduling Work in and Around Water Habitats in Tioweró:ton

## Purpose

These Best Management Practices are intended to serve the following purposes:

- To encourage appropriate environmental protection, mitigation of damage, and site restoration in the planning and implementation of all work carried out in or near water habitats in our territories; and
- To provide a resource that will guide and support MCK, private contractors, and individuals conducting any activities in or near water habitats.

The driving forces that guide the development and use of this handbook include the following:

- Fulfilling our traditional responsibilities to our Mother the Earth and ensuring that the cycles of life continue for future generations;
- Meeting the expectations of the community to protect our environment; and
- Respecting formal laws, guidelines and common sense practices intended to protect our water habitats.

Today most jurisdictions possess laws to protect water habitats. In other jurisdictions such as Canada for example, the Fisheries Act prohibits any work or undertaking that would result in “the harmful alteration, disruption or destruction of fish habitat” (Section 35(1)). The Fisheries Act also prohibits the deposit of “deleterious substances in any type of water frequented by fish or in any place under conditions where the deleterious substance may enter any such water.” (Section 36(3)). Deleterious substances can be defined as pollutants such as gasoline, oil, paints, chlorine, and vehicle wash water, or other materials that can harm fish life such as sediments or nutrients.

Although Kahnawà:ke does not possess formal laws similar to the Fisheries Act, this handbook is based on our traditional responsibilities to protect our Mother the Earth, and provides a solid foundation to guide us when carrying out work in or near our water habitats.

These Best Management Practices can guide ALL projects taking place in and around water habitats. However, it is important to note that larger-scale projects to be carried out in the St. Lawrence River and St. Lawrence Seaway, or on major highways will be subject to additional environmental mitigation measures as prescribed by the relevant funding agencies, proponents, or stakeholders.

This handbook is a “living document” that will be updated as improvements are recommended or new information on Best Management Practices becomes available.

## Overview

This handbook has been divided into three sections.

Part 1. Water Habitats in Kahnawà:ke & Tioweró:ton: This section provides information about the water habitats in Kahnawà:ke & Tioweró:ton and their natural attributes. Areas that have particular ecological importance are highlighted.

Part 2. Potential Impacts of Activities In or Near Water Habitats: This section lists examples of activities undertaken in or near water habitats and outlines their potential impacts. These impacts can be minimized by implementing the Best Management Practices presented in Part 3.

Part 3. Best Management Practices for All Stages of a Project: This section provides a set of Best Management Practices to guide activities in or near water habitats for all stages of a project, from project planning and scheduling, education and training, project implementation, monitoring and site restoration.

The Appendices provide additional information on the following topics:

- A. Appropriate plant species to be used in re-vegetation efforts
- B. Invasive plant species that workers should become familiar with in order to address their specific removal requirements
- C. Suppliers of mitigation products
- D. Important contact numbers

## Glossary of Terms

**Best Management Practices (BMP's):** Practices that are developed based on known science and determined to be the most technologically and economically feasible means of preventing and/or managing potential environmental impacts.

**Buffer:** Natural areas of grasses, shrubs and trees that shelter sensitive water habitats from adjacent land usages.

**Erosion:** The wearing-away of soil and/or rock by water and/or wind action.

**Fish Habitat:** Spawning grounds and nursery, rearing, food supply and migration areas on which fish depend directly or indirectly in order to carry out their life processes.

**Geotextile Membrane:** A synthetic material used under and over fill piles to prevent contamination and sedimentation of the surrounding environment, and under erosion control material with the primary functions of layer separation, aggregate confinement and distribution of load.

**Mitigation:** Actions taken during the planning, design, construction, and operation of a project to alleviate or reduce potential adverse effects on fish habitat, such as culvert design modifications to allow fish passage, timing constraints for in-stream work, and erosion control measures.

**No Net Loss:** A working principle which strives to balance unavoidable habitat losses through mitigation and habitat replacement. This document applies the “no net loss” principle to the loss and replacement of healthy native vegetation around water habitats.

**Watercourse:** Any flowing body of water.

**Wetland:** Land that is flooded or saturated with water for at least a portion of the year resulting in wet-altered soil and water-tolerant plants. Wetlands evolve over time (become bigger or smaller, more or less saturated). They can change depending on natural factors such as the seasons, the weather, and beaver activities, or by nearby human activities that impact on the natural drainage of the land. In some situations, wetlands are created by human activities. Over time, these sites evolve into naturally functioning wetland systems and are classified accordingly. In most instances, beaver-flooded areas are also classified as wetlands. However, where the flooding is causing damage to property, roads, or other valued structures, and an active program exists to locally extirpate the beaver, the beaver flooded portion of the wetland is not considered for inventory.

## PART 1: Water Habitats in Kahnawà:ke and Tioweró:ton

Kahnawà:ke and Tioweró:ton host an important diversity of water habitats including wetlands, creeks, bays, lakes, and rivers, as well as the banks and shorelines linking the water habitats to the land. Our water habitats are described below.

### *Wetlands*

Land that is flooded or saturated with water and results in wet-altered soil and water-tolerant plants is called a wetland. In Kahnawà:ke, wetlands are located both along the St. Lawrence shoreline and inland. We have four different types of wetlands in our community: swamps, marshes, shallow water wetlands, and peatland fens.

In March of 2008, the Environment Protection Office, in partnership with Ducks Unlimited Canada, conducted a study of wetlands in the community. This study identified a total of 1025 wetlands in our community, covering approximately one-fifth of our community. The following map shows locations of wetlands in Kahnawà:ke.

Figure 1: Kahnawà:ke Wetland Inventory Map

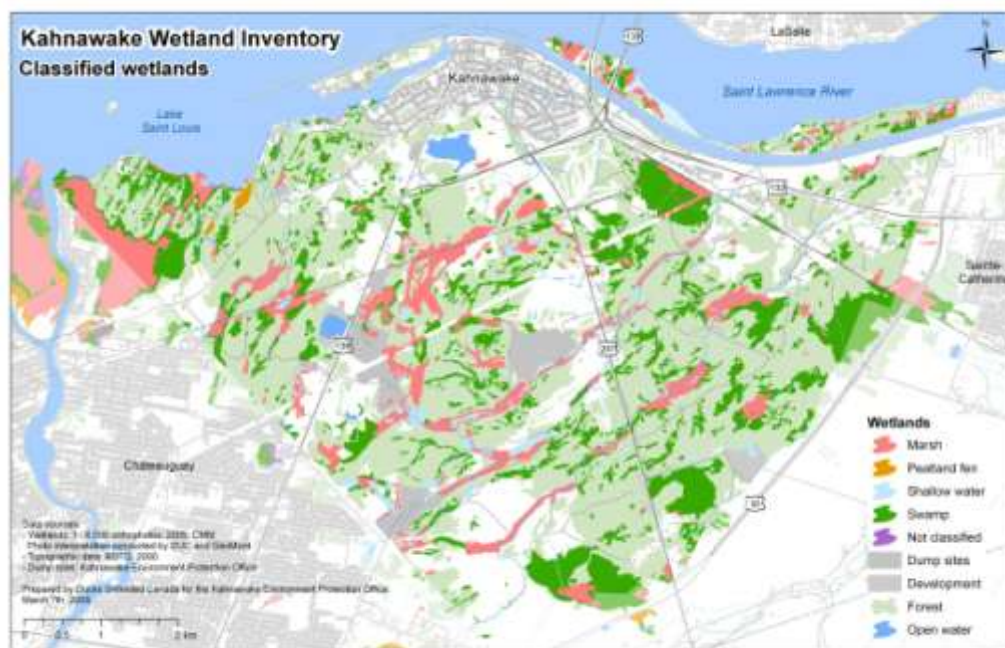



Wetlands are dynamic, meaning that they naturally change over time because of seasonal variations, weather or animal activities (ex. beavers). In most instances, beaver-flooded areas are classified as wetlands. However, where the flooding is causing damage to property, roads, or other valued structures, and an active program exists to locally extirpate the beaver, the beaver flooded portion of the wetland is not considered for inventory.

Human activities also impact on the natural drainage of the land and have been accelerating the degradation of wetland habitats. Of the 1025 wetlands in Kahnawà:ke, 65% of these are threatened because of human activities such as infilling for housing or commercial development, road and infrastructure development and maintenance, as well as recreational activities.

While natural processes and human activities cause the destruction or degradation of existing wetland habitats, displaced water will move to another location. This can create wet areas in new locations that may evolve into naturally functioning wetland systems or can lead to flooding of property, increased downstream erosion, or other unintended impacts on the disturbed property or adjacent landowners.

It is important to reduce harm to our wetlands, not only for their intrinsic value to countless species of plants and wildlife, but also for the many benefits wetlands provide to humans. For example:

- Wetlands are *natural filters* that improve water quality by filtering out pollutants from water flowing into the lakes, streams, rivers and groundwater.
- Wetlands *recharge ground water* and help *reduce flooding and erosion* by acting like sponges to absorb and store excess surface water, which is held in wetland plants and soils and released slowly into streams, rivers and groundwater when rainfall is less plentiful.
- Wetlands offer a source of *food and medicine*, such as berries, mushrooms, edible plants and fish. Medicines such as golden thread and sweet flag (onennó:ron) can be found in and around wetlands in Kahnawà:ke.
- Wetlands remove and store greenhouse gases and *reduce the impacts of Climate Change*.
- Wetlands provide *recreational and learning opportunities*. People who fish and hunt can appreciate the importance of wetlands. Wetlands create an “outdoor classroom” for students to learn about our natural world.
- Wetlands also provide us natural spaces for tranquility, relaxation and connection, which is good for our *physical, mental and spiritual health*. People need healthy environments to be healthy themselves.

Some economic estimates have shown that one acre of healthy wetland can provide up to \$10,000 worth of economic benefits and ecosystem services including filtering and recharging drinking water, preventing flooding and erosion, and providing habitat for many species<sup>1</sup>.

---

<sup>1</sup> <http://www.ecoevaluator.com/environment/water-quality/the-value-of-wetlands.html>

A vision for the sustainable and long-term protection for our wetlands must balance economic development needs and wetland conservation. The Wetland Evaluation Guide (1992)<sup>2</sup> is a tool that can be used to rate and compare the overall value of a specific wetland versus the value of a project proposed for that location. Using an objective evaluation method can guide decision-making for allowing a project to proceed as-is, with modifications, or moving the project to a less sensitive habitat. Such an evaluation would be part of an Environmental Impact Assessment process, which should be carried out before applying Best Management Practices for Working in and Around Water Habitats. The Environment Protection Office can help community organizations and landholders to identify wetland habitat, assess impacts, and provide alternatives to minimize the disturbance of these wetlands. Ideally, new construction should avoid wetland areas as these sensitive ecosystems are easily disturbed and the soil found in these areas is typically not suitable for construction resulting in high costs associated with importing fill and potential future problems with long-term settlement of the organic soils below. A setback distance of 30 m from an adjacent wetland is the optimal way to reduce negative impacts to this habitat and prevent additional maintenance associated with your lands.

Figure 2: Wetland Habitat in Kahnawà:ke



<sup>2</sup> [http://www.env.gov.bc.ca/wld/documents/WEG\\_Oct2002\\_s.pdf](http://www.env.gov.bc.ca/wld/documents/WEG_Oct2002_s.pdf)

## ***Rivers and Creeks***

Kahnawà:ke relies on a large amount of water resources, including a complex network of creeks that drain into the St. Lawrence River and Lake St. Louis to the north. The St. Lawrence River originates in Lake Ontario and flows past our community to the Atlantic Ocean. All water sources work together within a large watershed. A watershed is an area drained by a river and its water branches. Kahnawà:ke is included in the larger Chateauguay River watershed area. Our location has a slow-moving freshwater ecosystem with a large floodplain.

Like wetlands, rivers and creeks are dynamic ecosystems, meaning that they naturally change throughout time. With people living so close to the St. Lawrence River and the creeks, some people have adopted the practice of diverting the water or installing barriers to avoid damage to property. This practice works against the natural tendency of the water to change its path. This is a reality that we must manage today.

The quality of the water and sediment in the river and creeks is being impacted due to runoff from pollutants originating from towns upstream, as well as from our own community (pesticides, oils, heavy metals, storm water, sewage overflows, leaking septic tanks, etc.). In addition to pollutants, garbage and debris enter the river and creeks causing destruction of habitat and physical harm to aquatic species.

Work taking place in and around waterways for dredging, “cleaning”, or creek crossings can cause significant damage to river and creek ecosystems, especially when heavy machinery is involved. These practices can also increase erosion and sedimentation, and damage spawning habitats.

Figure 3: Heavy Machinery in Creek Habitat in Kahnawà:ke



Creek crossings, if not done properly, can alter the flow, add debris and sediment to the waterway, and prevent or hinder the movement of aquatic species. Work in and around water can also introduce and spread invasive species that can damage the habitat and crowd out native species.

We have an important responsibility to protect our river and creek habitats, which perform the following vital functions:

- The plants in and around rivers and creeks *improve water quality* by filtering pollutants.
- The St. Lawrence River is the source of our *drinking water*.
- Rivers and creeks are integral parts of natural *storm drainage systems*.
- Rivers and creeks provide *habitat for a wide variety of aquatic species* like fish, mollusks, birds, insects, mammals, reptiles and amphibians.
- Fish from the river are traditionally an *important source of food* for the community and income for local fishermen.
- Our river and creeks provide *educational opportunities* for students to learn about the variety of life that our waters support and how they can work to protect these habitats.
- Rivers and creeks are natural spaces for tranquility, relaxation and spiritual connection that come from our strong connection to the waters. This helps our *physical, mental and spiritual health*.
- Water in our creeks infiltrates into the ground, eventually becoming drinking water for members of our community relying on wells for their water.
- The river is an important *gathering place* for families and friends to socialize get physical activity and enjoy nature. It also provides valuable *recreational opportunities* for our community such as boating and swimming, as well as water sports and regattas.

Every living thing needs clean water to survive. Conservation of our river and creek habitats will require combined community efforts to ensure the protection of our water resources for the current and future generations. Cooperative efforts are especially important for the people living near water and the Mohawk Council of Kahnawà:ke departments who carry out work in and around our waterways.

Figure 4: Healthy Creek Habitat Flowing into the Little Suzanne River



## *Shorelines*

Shorelines link the water and land habitats. They are one of the most dynamic and productive ecosystems on earth. Shorelines are sometimes called the “ribbons of life” because they support countless land and water species. When a shoreline is healthy and vegetated with native plant species, it provides shade, shelter and food, controls erosion and filters pollutants. The water’s edge also provides spawning areas, shelter and food for fish, reptile, amphibian and insect species.

In 2007, the Environment Protection Office carried out a shoreline study to map out and characterize our shoreline habitats. Kahnawà:ke’s diverse shoreline habitats range from completely artificial along the seaway, lawns and bare soil, to natural shoreline marshes, forested shorelines and bedrock at the “flat rocks”. We have many high quality shoreline habitats that are quite rare in the region, especially those on the North Wall bordering the St. Lawrence River, and around the Big Fence area. Other shoreline areas and creek banks are in need of restoration to bring them back to a healthy state.

Land filling or removing natural vegetation from a shoreline or creek bank increases land erosion and sends silt and sediment into the water where it damages spawning areas, changes water flow, and creates blockages. See the sections entitled “Vegetation Management” and “Fill Management” in Part 3 of this handbook, for guidance on managing vegetation and fill near water.

Figure 5: Landfilling on Shoreline Habitat in Kahnawà:ke



Maintaining clean and garbage-free shores and creek banks is important. However, NATURAL fallen debris such as logs, branches, and rocks should be removed only if it is causing danger or impeding the flow of the water. Clearing all the natural fallen debris can cause unintended negative effects by removing important habitat used by many different species. Logs, branches and rocks should be left in place to maintain habitat.

Features of a healthy shoreline or creek bank include a strip of native trees, shrubs, or other shoreline plants, a mixture of natural rocks and soil, and some fallen debris like logs used for shelter. This photo near McGregor farm demonstrates a healthy creek bank.

Figure 6: Healthy Creek Habitat Near McGregor Farm



Maintaining a natural vegetated buffer on the shoreline or creek bank will help these important ecosystems to perform their valuable functions. For example:

- Buffers are *natural filters* for the watershed. The vegetation on a shoreline or creek bank reduces runoff water velocities allowing sediment to settle out and stabilize on the banks and absorbing excessive nutrients from the runoff.
- Buffers also prevent bank erosion. Vegetation prevents topsoil from getting washed into the creek while roots from trees and shrubs hold the creek banks together, preventing massive slope failure.
- Natural lands around watercourses act as floodplains during periods of high flow. Allowing water from the creek to spill onto the floodplain reduces the erosive energy of the water protecting the main channel of the creek. Natural floodplains also temporarily hold water reducing flow peaks caused by intense rain storms thereby preventing flooding of downstream properties.
- Maintaining a natural shoreline and creek bank vegetation is one of the most important and least expensive ways to *protect your property* from erosion, and attract wildlife.
- The shoreline and creek bank provide *habitat for a wide variety of species*, including birds, reptiles, amphibians, insects, mammals, fish, and other aquatic species. In fact, 90% of all living things in a lake or river are born, raised and fed along the shoreline.
- Shorelines are places to enjoy the beauty of our waterways, which improves our *physical, mental and spiritual health*.
- Shorelines and creek banks provide *educational opportunities* for students to learn about the variety of life that these fragile ecosystems support and how they can work to protect these habitats.

Conservation and restoration of our river shorelines and creek banks will require a cooperative working relationship between the Environment Protection Office, individual community members, and the Mohawk Council of Kahnawà:ke departments who carry out work on or near our waterways. These Best Management Practices are an important step towards this goal.

## ***Environmentally Sensitive Habitats in Kahnawà:ke***

Throughout the last decade, the Kahnawà:ke Environment Protection Office has been carrying out species inventories and characterizing our habitats to assess the status of the natural areas in our community. Based on these studies, several habitats with unique ecological value have been identified as priority areas for protection or restoration. Particular care should be taken to protect the water habitats in these areas, and any work planned in or near these sensitive habitats should undergo review by the Environment Protection Office, for recommendations on mitigating damage.

1. **Johnson's Point/Big Fence Area:** This area is located at the north-west of our Territory, by Lake St Louis.
2. **The North Wall Area:** This area is located along the St Lawrence River on a piece of land divided from the mainland by the St Lawrence Seaway canal.
3. **Tekakwitha Island, Recreational Bay and Bike Paths:** Connected to our community by a bridge, the Island is located north-west of the central village area. The Recreational Bay is the primary recreational water space in the community and is surrounded by bike paths on either side.

### *Johnson's Point / Big Fence Area*

The common land in this area occupies approximately 666 acres of forest, shoreline and wetland habitats. Approximately 46% of this area is occupied by wetlands. All four of the wetland types in Kahnawà:ke are found in the Johnson's Point / Big Fence area. The rest of the area is occupied by forest stands including old growth sugar maple forest and tolerant hardwood like Sugar maple, Silver maple, Red oak, Bitternut, American basswood and Bur oak. This area also has moist deciduous forest including Red maple, Silver maple, Green ash, Elm and ferns.

Three (3) plants at risk have been confirmed in this area (Butternut tree, May apple and Wild leek/garlic). Sixteen (16) mammal species are likely found in the Johnson's Point/Big Fence area, including beaver, muskrat, otter, red fox and white tailed deer. One hundred and forty-eight (148) bird species have been identified in this area, including two birds at risk, the Bald Eagle and the Caspian Tern. Eight (8) species of amphibians and reptiles have been found in this area, including the Northern leopard frog, Green frog, Wood frog, Northern spring peeper, Blue-spotted salamander, Painted turtle, Garter snake and the Snapping turtle.

Because of its prime waterfront location, the private land in the Johnson's Point / Big Fence area has undergone residential development. The shoreline and nearby forest are impacted by land filling, deforestation, clearing of paths or dumping of waste. These actions threaten the survival of the habitat and species of plants and animals that live there. The surrounding common land is an important part of our natural heritage that should be prioritized for protection for future generations.



Figure 7: Map of Johnson's Point / Big Fence Area

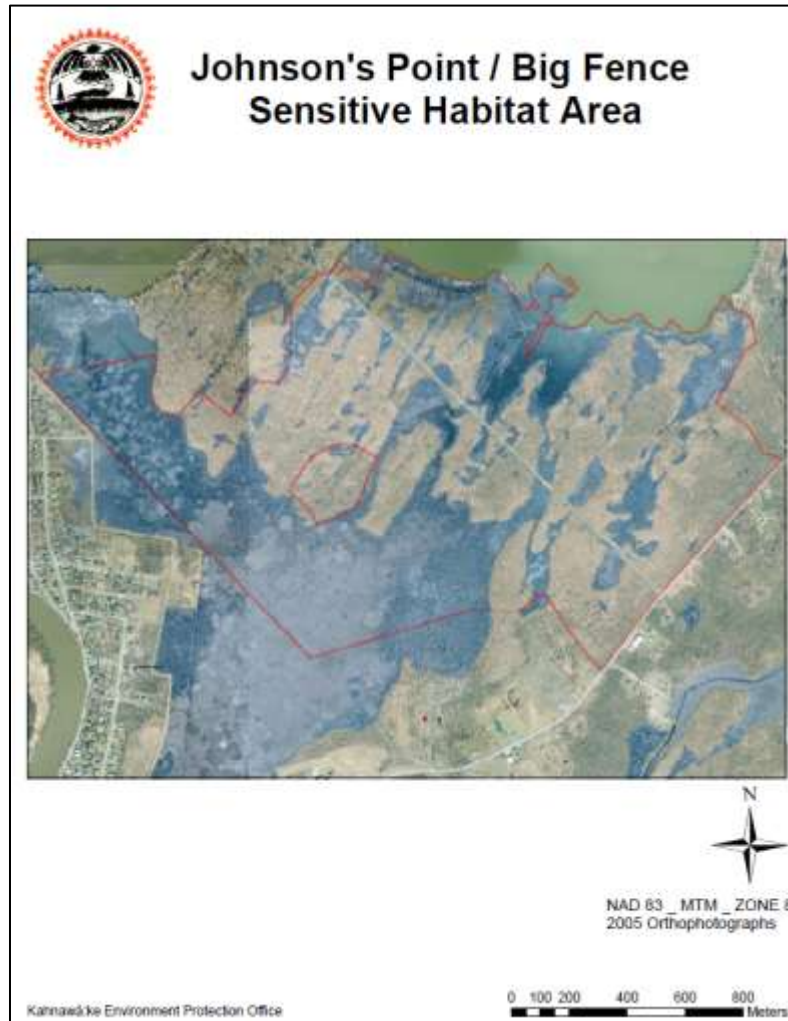

### *The North Wall*

The North Wall has two distinct sections, east and west, connected by an access road and a shoreline marsh. The eastern section occupies an area of about 504 acres and the western section occupies about 311 acres. All the lands of the North Wall are common with both sections made up of wetlands, including swamp, marsh and shallow water.

The eastern area of the North Wall has forest stands that are mainly moist deciduous forest dominated by American basswood. Large willows grow along the shoreline. Old streambeds are still there and provide habitat to a colony of Lizard's tail, a plant at risk. Butternut trees, another plant at risk, are identified in the area. Fifteen (15) different mammal species are likely to be seen in the eastern area of the North Wall including the eastern cottontail, long tailed weasel, mink and raccoon. Likely to be found in this area are one hundred and forty-eight (148) different bird species, including the Great blue heron, Great egret, Wood duck, and Ruffed grouse. At least six different species of reptiles and

amphibians also live in this section of the east North Wall including the Snapping turtle, Mudpuppy and Two-lined salamander.

The western area of the North wall has forest stands of mostly moist deciduous forest dominated by eastern cottonwood. The “flat rocks” near the Mercier Bridge is called an Alvar, and is considered a rare ecosystem. The flat rocks have flat limestone rock that undergoes temporary flooding and dry periods. Scrublands in this area are mainly fields with sumac and goldenrod. Seventeen (17) mammal species are likely to be seen in this area including the red fox, northern short-tailed shrew and star nosed mole. Likely to be found in this area are one hundred and forty-eight (148) different bird species, including the Peregrine falcon, a species at risk. At least seven (7) amphibian and reptile species live in the area including the Wood frog, Painted turtle, Snapping turtle, Garter snake and Eastern red-backed salamander. An important Lake sturgeon spawning ground is in the river near this area.

Figure 8: Map of the North Wall Area

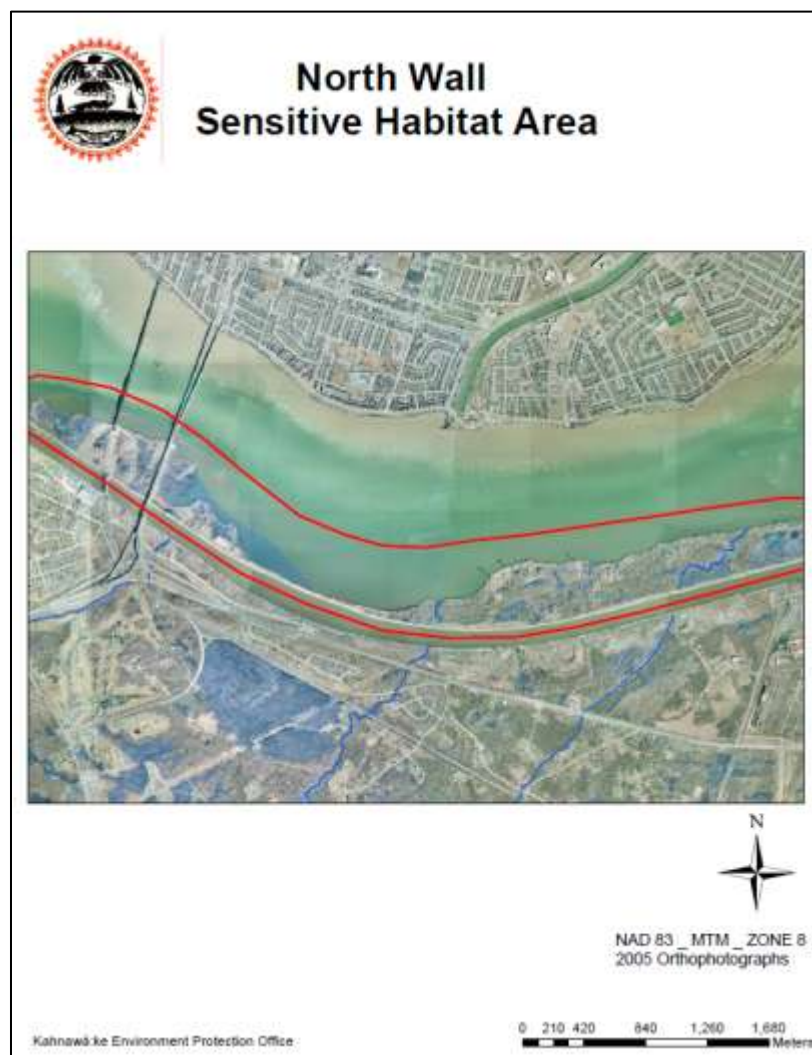

## *Tekakwitha Island, Recreational Bay and Bike Paths*

Originally, Tekakwitha Island was the site of five (5) islands of different sizes. When digging up the St Lawrence Seaway, the dredged material was dumped onto these islands to create the one island we know today.

Tekakwitha Island has some unique and important habitats, including an important shoreline habitat that remains from one of the original islands. This area is a particularly sensitive habitat that many different species rely on for their survival. The Brown snake, a rare snake in Quebec, makes its home in the rocky fields of Tekakwitha Island.

The shoreline of the Island does not have much vegetation, making it sensitive to soil erosion. There are many opportunities for shoreline restoration on both sides of the Recreational Bay.

Figure 9: Map of Tekakwitha Island, Recreational Bay and Bike Paths



## ***Environmentally Sensitive Habitats in Tioweró:ton***

About thirty lakes of small to medium size can be found within the Tioweró:ton territory, many of which support a local population of brook trout.

Coniferous forests are mostly found on the Doncaster-River plain. Balsam fir or cedar-spruce forests are common in this particular environment. Bogs and alder are present in surrounding water plains. Deciduous forest groupings are generally found on hill slopes including tolerant hardwood-maple and intolerant hardwood maple forests, as well as some mixed forests. Some species that rely on the habitats in Tioweró:ton include moose, deer, ruffed grouse, American marten, American woodcock and the pileated woodpecker.

The most sensitive habitats in Tioweró:ton include bogs, cedar wood, black spruce wood and alder wood; humid uncovered terrains with poor or no drainage, or any sites located less than 20 meters from a water body and mature forest stands.

Many important bogs are present in Tioweró:ton territory. During a study in 2004-2005, it was found that many of these bogs were rather thick. This characteristic indicates a very high sensitivity level for these environments. Unfortunately, many sensitive habitats are disturbed by ATV circulation.

Figure 10: Creek Habitat in Tioweró:ton Disturbed by All Terrain Vehicles



The riverside of Doncaster River is also considered as an important sensitive zone. This zone was subjected to disturbances and alterations, resulting from the construction of cottages. Approximately 10% of the cottages presently constructed in Tioweró:ton are located very close to the riverside of Doncaster River and one of its tributaries.

Soil erosion resulting from the construction of forest roads constitutes one of the worst problems of degradation for aquatic habitats in Tioweró:ton. Forest road constructions may cause soil erosion especially at river crossings and this may involve the release of fine particles in aquatic environments. Consequently, planning of new roads should be made with as little river crossings as possible. Wherever river crossings cannot be avoided, Best Management Practices should be used and the stabilization of bare soil should be prioritized in order to preserve the quality of the aquatic environments.

Figure 11: Creek Crossing in Tioweró:ton Experiencing Erosion Problems



## PART 2: Potential Impacts of Activities In or Near Water

Water habitats are very important ecosystems, providing food, nesting sites, and shelter for a variety of fish, mammals, birds, amphibians, and reptiles. Water is also valuable to humans for clean drinking water and drainage. The most sensitive part of the ecosystem includes the water body itself and the adjacent bank or riparian zone.

Figure 12: Components of the Water Ecosystem that are Sensitive to Disturbances

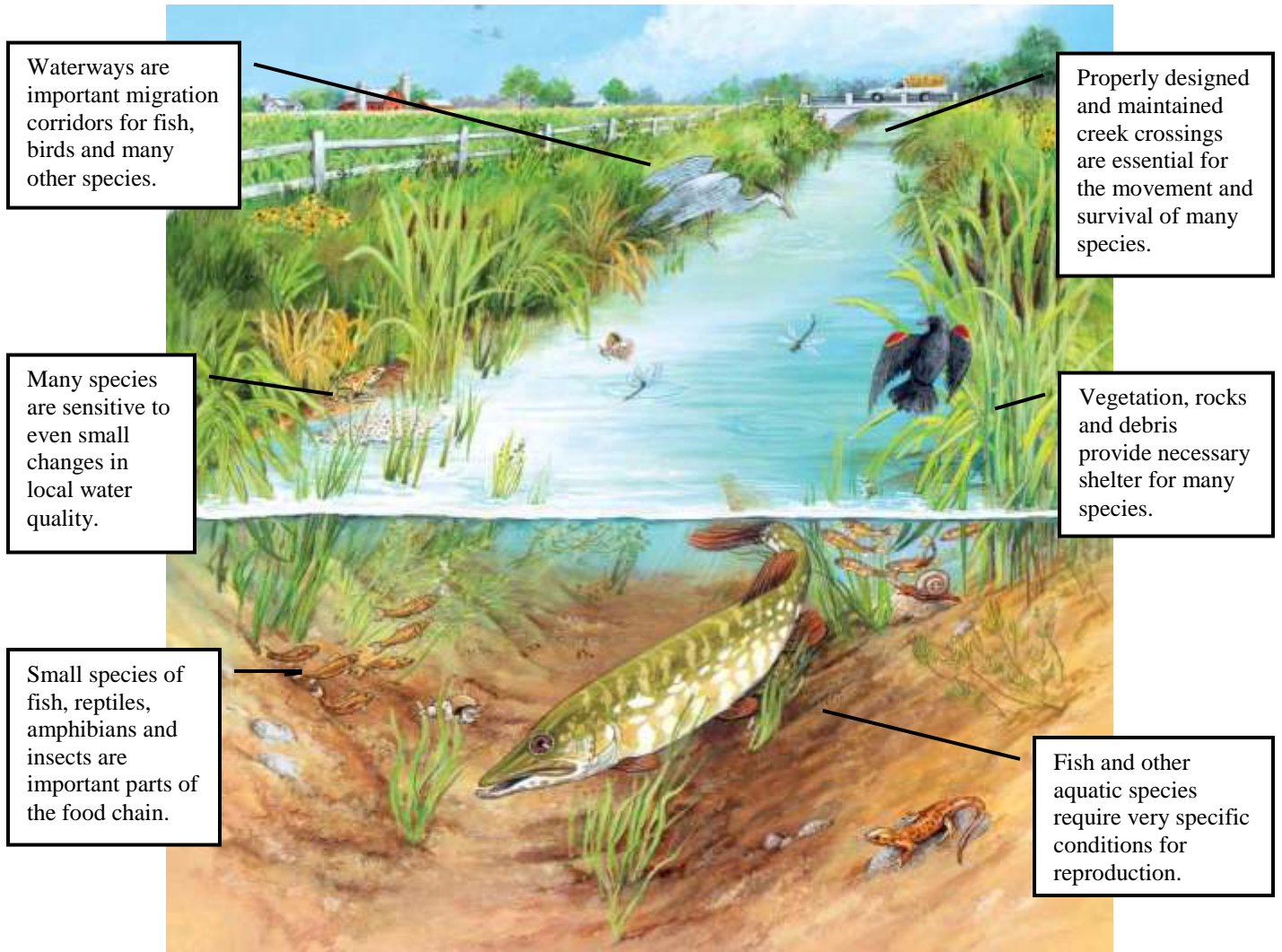

Source of image: Fisheries and Oceans Canada (2008). The Drain Primer.

Work taking place in these areas should follow Best Management Practices in order to protect and enhance the important natural functions of our water ecosystems. Table 1 presents examples of how certain activities taking place in or near waterways may impact the delicate natural balance required for life. Part 3 will present the Best Management Practices to follow to for all stages of a project to minimize harm to the natural environment.

Table 1: Examples of Activities Near Water and their Potential Environmental Impacts

Activity	Potential Environmental Impacts
<p><b><i>Creek, Ditch and Shoreline Maintenance</i></b></p> <p>Includes the cleaning and maintenance of waterways and drainage structures (ex. debris removal from creeks and culverts) as well as from shorelines and creek banks.</p>	<p>Maintenance of creeks can be important to remove blockages to flow and human debris. However, cleaning that is too intensive can damage habitat by removing shelters or destroying spawning and feeding grounds for a wide variety of aquatic species. The removal of vegetation during creek maintenance can also cause bank instability, erosion, sedimentation, changes in the current speed, and deterioration of the water quality.</p> <p>Some debris found in waterways, particularly large woody debris, can provide important cover for fish and other aquatic organisms, and its removal may reduce a waterway’s fish habitat value.</p> <p>If debris removal activities release sediment (gravel, sand and silt) or other contaminants into a waterway, this may:</p> <ul style="list-style-type: none"> <li>• Directly affect fish through exposure to contaminants or indirectly through changes in habitat.</li> <li>• Reduce the number and diversity of bottom dwelling organisms as sediment collects on the bottom of the water body.</li> <li>• Clog fish spawning areas with sediment.</li> <li>• Reduce the survival of eggs and newly-hatched fish by smothering them in sediment.</li> </ul> <p>Machinery, equipment and vehicles used in debris removal that are operated in or near a waterway or on a waterway’s banks may cause significant harm to banks, vegetation and bottom material; decrease bank stability; and leak or spill fuel or hydraulic fluids into the waterway, affecting fish, other aquatic organisms and vegetation.</p>

Activity	Potential Environmental Impacts
<p><b><i>Creek Crossings</i></b></p> <p>Includes any work that involves crossing through, under, or over a creek such as the installation of water or sewage pipes, road construction, culvert construction, culvert replacement or repairs, etc.</p>	<p>Creek crossings for roads or pipes often result in impacts to aquatic habitats, especially during the construction phase. Machinery, equipment and vehicles used during construction may cause significant harm to banks, vegetation and bottom material; decrease bank stability; and leak or spill fuel or hydraulic fluids into the waterway, affecting fish, other aquatic organisms and vegetation.</p> <p>The removal of vegetation on the creek bank, inappropriate creek crossing designs, and poor maintenance of culverts can also cause significant disruptions to the natural processes occurring in the stream. Some of these impacts include:</p> <ul style="list-style-type: none"> <li>• Bank instability, erosion and sedimentation</li> <li>• Destruction or loss of habitat</li> <li>• Barriers to the passage of fish and other aquatic organisms</li> <li>• Reduction in water quality</li> <li>• Alterations in flow or blockages resulting in flooding</li> </ul> <p>All of these impacts may result in significant declines in the populations of aquatic species and prevent them from fulfilling their basic needs for life in the stream as well as creating the need for expensive repairs and high maintenance costs.</p>
<p><b><i>Excavation and Relocation of Soil</i></b></p> <p>Involves the excavation of soil for the purpose of carrying out maintenance or infrastructure projects, followed by the relocation of that soil to another area.</p>	<p>Soil that is excavated from a project site has the potential to contain contaminants from past dumping activities or from the long term deposition of pollutants. The community has many known contaminated sites as well as areas of suspected contamination, including but not limited to:</p> <ul style="list-style-type: none"> <li>• Known contaminated sites and adjacent properties</li> <li>• Areas adjacent to transportation corridors</li> <li>• Properties with past or present dumping, scrap car storage, garages, gas stations, snow dumping and their adjacent lots</li> </ul> <p>When soil is relocated to other areas in the community, without firm knowledge of the soil quality, it may release contaminants into the surrounding environment (soil, groundwater, surface water and sediment) and cause negative health impacts to humans and the natural environment.</p>



Activity	Potential Environmental Impacts
<p><b><i>Asphalt Resurfacing</i></b></p> <p>Involves activities such as the removal of existing road surfacing materials (asphalt, waterproofing membranes, cement curbs) and replacement or repair with new surface materials on roads and bridge surfaces.</p>	<p>Materials used for asphalt resurfacing (both new and waste materials) have the potential to harm fish, other aquatic organisms and vegetation if they are allowed to enter a waterway. As such, they are considered to be deleterious substances. Materials of concern include, but are not limited to:</p> <ul style="list-style-type: none"> <li>• Asphalt (both new and waste)</li> <li>• Oils</li> <li>• Sealants, paints or other surface treatments</li> <li>• Concrete, or other cement-based products</li> </ul> <p>Asphalt resurfacing also involves the use of machinery. When operated near waterways, equipment may accidentally release compounds that are harmful, such as fuels or hydraulic fluids.</p> <p>During the removal of existing road surfaces, sediment (gravel, sand and silt) comprising the roadbed may be washed into a waterway where it can harm fish, aquatic organisms and vegetation.</p>
<p><b><i>Landfilling</i></b></p> <p>Involves any introduction of foreign material or soil (construction debris, excess soil from another job site) to a new location including direct placement within a watercourse or wetland.</p>	<p>Landfilling has the potential to be one of the most detrimental activities to our watercourses and wetlands. Clearly, if these areas are filled in they will no longer be able to provide us with their beneficial human and environmental functions. Landfilling activities near watercourses and wetlands should be avoided with recommended buffer areas of fifteen and thirty metres respectively. Implementation of appropriate sediment and control measures around landfilled areas are also important to prevent the migration of materials including sediment into the waterways.</p>

## PART 3: BMPs for All Stages of a Project

As demonstrated in Table 1 of the previous section, all work carried out in and around a water habitat has the potential risk of affecting water quality and quantity, fish and other aquatic organisms, and their habitats. Primary impacts are associated with the discharge of contaminants and pollutants, reductions in flow, removal of vegetation, and the physical alteration of the watercourse and banks. Some of these effects may not directly or immediately kill fish or other wildlife, but they are still significant because they weaken populations over time.

Best Management Practices (BMPs) are recommended techniques and guiding statements that, when followed, will allow you to undertake works in and around water habitats in a manner that will avoid, minimize or mitigate impacts to aquatic and riparian habitats, water quality and quantity, fish and wildlife species, and public safety and property.

The core principles of Best Management Practices are the following:

AVOID → MINIMIZE → MITIGATE → RESTORE

This section provides guidance on how to plan for and implement these principles during all stages of a project, for routine operations and maintenance activities along waterways and watercourses in Kahnawà:ke and Tioweró:ton.

### *Project Planning and Scheduling*

Communication with the Kahnawà:ke Environment Protection Office during the early stages of project planning and scheduling can go a long way towards avoiding environmental impacts of work in or around water. Proactive planning and scheduling can also avoid costly project-delays.

#### *Project Planning*

When developing a project work plan that will involve work in or around water, follow these Best Management Practices:

1. The first approach in project planning is to avoid any development or maintenance activities in water habitats, if possible. This will reduce the amount of planning required to protect the water habitat.
2. If the activities cannot be avoided, the next approach would be to minimize and mitigate any environmental damage that may occur as a result of the work in or around the water, and incorporate restoration activities in the work plan.



3. Begin project planning early to allow adequate time for alternatives to be discussed and appropriate environmental mitigation measures to be determined and incorporated into the project budget and work plan.
4. Some examples of mitigation costs to include in a project budget are lab analysis fees for fill that will be moved from the project site, impermeable membranes to put under and over stockpiled soil, disposal fees at a licensed facility for any contaminated soil, silt fences to prevent sedimentation in watercourses, etc. Refer to the following sections in this guide for more detailed information related to your specific project.
5. Some examples of restoration costs to include in a project budget are topsoil, and native species of plants, shrubs, and trees for re-vegetation efforts. Refer to the following sections in this guide for more detailed information related to your specific project.
6. When planning for creek maintenance activities, visit the creeks to be maintained and note the site conditions including healthy sectors, sensitive or important habitats, challenges, obstructions, debris, invasive plants (ex. *Phragmites*, Purple Loosestrife, etc.), and any other issues of importance. Environment Protection staff can accompany the creek maintenance technician, if requested, to highlight important environmental characteristics.
7. Communicate with the Kahnawà:ke Environment Protection Office (KEPO) regarding questions or uncertainties about projects in or around any type of water habitat. Review and recommendations on draft project plans can be provided.

### *Project Scheduling*

Project scheduling should take into account periods of low risk to fish and wildlife species. For example, sediment or debris removal from water should occur during periods when flow is absent or minimal. Spawning periods occur March through July in Kahnawà:ke, and September to June in Tioweró:ton. NO in-water work should be conducted during spawning periods. Refer to the tables below to schedule projects during periods of low risk of impact for any work in or around water habitats in Kahnawà:ke and Tioweró:ton:

Table 2: Scheduling Work in and Around Water Habitats in Kahnawà:ke



Activity	Jan	Feb	Mar	Apr	May	Jun	Jul	Aug	Sep	Oct	Nov	Dec
Any invasive work in creeks such as creek crossings								*	*	*	*	*
Shoreline / bank stabilization	*	*						*	*	*	*	*
Vegetation disturbance on shorelines & creek banks	*	*						*	*	*	*	*
Cleaning in creeks (sediment or debris removal)								*	*	*	*	*

Low risk of impact  \* Work should be carried-out during periods of low risk  
 Medium risk of impact   
 High risk of impact 

It is very important to note that spawning occurs at different times in Tioweró:ton (September-June) than in Kahnawà:ke (March-July). In Tioweró:ton the least impact will occur for work scheduled during July and August. The following scheduling guidelines should apply in Tioweró:ton.

Table 3: Scheduling Work in and Around Water Habitats in Tioweró:ton

Activity	Jan	Feb	Mar	Apr	May	Jun	Jul	Aug	Sep	Oct	Nov	Dec
Any invasive work in creeks such as creek crossings							*	*				
Shoreline / bank stabilization							*	*				
Vegetation disturbance on shorelines & creek banks							*	*				
Cleaning in creeks (sediment or debris removal)							*	*				

Low risk of impact  \* Work should be carried-out during periods of low risk  
 Medium risk of impact   
 High risk of impact 

## Project Design

Maintenance and development projects taking place around water should be designed to incorporate the most current environmental mitigation techniques prescribed by the relevant agencies, proponents, or stakeholders. The scope of project design is too large to incorporate within the context of this document, however a few general guidelines are presented here.

1. The design of a project should be adapted to the specific conditions of a site.
2. Project design can be significantly improved by consulting a wide cross-section of stakeholders, including the Kahnawà:ke Environment Protection Office.
3. Permanent creek crossings require particular design scrutiny because of the long-lasting effect they can have on water habitats. Permanent stream crossings should maintain free fish passage and minimize impacts on fish habitat. Although there are many possible alternatives for environmentally-sound creek crossing designs, some important characteristics are presented in Figure 13. Culvert sizing is one of the most important design considerations when creating a new crossing.

Figure 13: Characteristics of a Well-Designed Creek Crossing



Source: Vermont Fish and Wildlife. (2010) *Vermont Stream Crossing Handbook*.

## ***Education and Training***

These Best Management Practices will not be effective unless project planners, workers and landowners are aware of and comfortable with their implementation in the field. The following education should be carried out to ensure that workers have the tools and the knowledge to implement the BMPs:

1. Assign an employee to be the environmental liaison and person responsible for ensuring implementation of the BMPs. This can be for all projects or on a project-by-project basis.
2. Carry out an annual information session with the Public Works and Technical Services crews before the construction season, to review the Best Management Practices and discuss issues or recommend improvements to these practices. Any concerns about these practices should be discussed early in the planning stages so that alternatives can be sought, if needed.
3. Brief all employees on implementing the relevant Best Management Practices for the specific project they are assigned to.



4. Carry out periodic training on spill prevention and emergency spill clean-up to prevent spill incidents from occurring, and minimize damage to water habitats if spills of hazardous substances occur on the worksite.

Individual community members or businesses working in or near water should contact the Kahnawà:ke Environment Protection Office to obtain guidance on implementing these Best Management Practices. Education will also be carried out in the community.

## ***Work Site Management***

### ***Work Site Preparation***

Good site preparation activities can reduce the effects of erosion, slope instability and sediment discharge. BMPs for site preparation activities are presented below:

1. Ensure that an appropriate plan is in place prior to starting construction. This should include identification of vegetation protection areas (see section on Vegetation Management Procedures), a sediment and erosion control plan, a strategy for managing water on-site including identification of any possible water crossings or temporary diversions, and a fish rescue plan.
2. Install all sediment and erosion control measures first.
3. Install construction fencing around vegetated areas identified for protection.
4. Grade all fill placed on watercourse banks to ensure it is compact and contoured to the natural slope of the site.
5. Avoid clearing and grading on steep slopes, where possible. If such activity is required, ensure adequate erosion and sediment control measures are in place.
6. Consider re-using small woody debris to improve soil conditions, protect roots, and improve visual aesthetics of the work site.
7. Build well-designed temporary entrances and exits to construction sites in order to minimize impact on the water habitat. The use of crushed asphalt concrete should not be used as aggregate for road base in water habitats. Asphalt is a petroleum-derived material and contaminants may leach into the water as it breaks down.
8. Avoid stream crossings whenever possible. Consider alternative routes to accessing a site, but if a stream crossing is necessary, choose areas with the lowest potential for erosion. Although temporary creek crossings should be designed based on the specific site conditions, basic guidelines are provided in the following operational statement issued by Fisheries and Oceans Canada:

#### ***Measures to Protect Fish and Fish Habitat when Carrying Out a Temporary Stream Crossing<sup>3</sup>***

1. *Use existing trails, roads or cut lines wherever possible, as access routes to avoid disturbance to the riparian vegetation.*
2. *Locate crossings at straight sections of the stream, perpendicular to the bank, whenever possible. Avoid crossing on meander bends, braided*

---

<sup>3</sup> <http://www.dfo-mpo.gc.ca/habitat/what-quoi/os-eo/qc/crossings-eng.asp>

*streams, alluvial fans, or any other area that is inherently unstable and may result in the erosion and scouring of the stream bed.*

3. *While this Operational Statement does not cover the clearing of riparian vegetation, the removal of select plants may be necessary to access the construction site. This removal should be kept to a minimum and within the road or utility right-of-way. When practicable, prune or top the vegetation instead of uprooting.*
4. *Generally, there are no restrictions on timing for the construction of bridge structures or fording seasonally dry streambeds, as they do not involve in-water work. However, if there are any activities with the potential to disrupt sensitive fish life stages (e.g., fording of the watercourse by machinery) these should adhere to appropriate fisheries timing windows. [see Table 2 and Table 3 above for scheduling]*
5. *Machinery fording a flowing watercourse to bring equipment required for construction to the opposite side is limited to a one-time event (over and back) and is to occur only if an existing crossing at another location is not available or practical to use.*
  - 5.1 *If minor rutting is likely to occur, stream bed and bank protection methods (e.g., swamp mats, pads) should be used, provided they do not constrict flows or block fish passage.*
  - 5.2 *Grading of the stream banks for the approaches should not occur.*
  - 5.3 *If the stream bed and banks are steep and highly erodible (e.g., dominated by organic materials and silts) and erosion and degradation are likely to occur as a result of equipment fording, then a temporary bridge should be used in order to protect these areas.*
  - 5.4 *The one-time fording should adhere to fisheries timing windows. [see Table 2 and Table 3 above for scheduling]*
  - 5.5 *Fording should occur under low flow conditions, and not when flows are elevated due to local rain events or seasonal flooding.*
6. *Install effective sediment and erosion control measures before starting work to prevent the entry of sediment into the watercourse. Inspect them regularly during the course of construction and make all necessary repairs if any damage occurs.*
7. *For temporary bridges also employ the following measures:*



- 7.1 *Use only clean materials (e.g., rock or coarse gravel fill, wood, or steel) for approaches to the bridge (i.e., not sand, clay or organic soil) and install in a manner that avoids erosion and sedimentation.*
- 7.2 *Design temporary bridges to accommodate any expected high flows of the watercourse during the construction period.*
- 7.3 *Restore the bank and substrate to pre-construction condition.*
- 7.4 *Completely remove all materials used in the construction of the temporary bridge from the watercourse following the equipment crossing, and stabilize and re-vegetate the banks.*
8. *Operate machinery in a manner that minimizes disturbance to the watercourse bed and banks.*
  - 8.1 *Protect entrances at machinery access points (e.g., using swamp mats) and establish single site entry and exit.*
  - 8.2 *Machinery is to arrive on site in a clean condition and is to be maintained free of fluid leaks.*
  - 8.3 *Wash, refuel and service machinery and store fuel and other materials for the machinery away from the water to prevent deleterious substances from entering the water.*
  - 8.4 *Keep an emergency spill kit on site in case of fluid leaks or spills from machinery.*
9. *Stabilize any waste materials removed from the work site, above the high water mark, to prevent them from entering any watercourse. This could include covering spoil piles with biodegradable mats or tarps or planting them with preferably native grass or shrubs.*
10. *Vegetate any disturbed areas by planting and seeding preferably with native trees, shrubs or grasses and cover such areas with mulch to prevent soil erosion and to help seeds germinate. If there is insufficient time remaining in the growing season, the site should be stabilized (e.g., cover exposed areas with erosion control blankets to keep the soil in place and prevent erosion) and vegetated the following spring.*
  - 10.1 *Maintain effective sediment and erosion control measures until re-vegetation of disturbed areas is achieved.*

*This Operational Statement (Version 1.0) may be updated as required by Fisheries and Oceans Canada. It is your responsibility to use the most recent version.*

---

9. Remove any temporary access roads and stream crossings after the project is completed and remediate to pre-project conditions.
10. Remove all sediment control measures once the site has revegetated.

### *Work Site Isolation*

Proper work site isolation is an important way to minimize the risk of releasing deleterious substances.

1. Isolate your work area from any flowing water that may be present, but do not stop flow to downstream portions of the watercourse. Ensure water is temporarily diverted around the portion of the watercourse where you are working.
2. For works using chemically active substances, such as cement-based products, paints, epoxies, or other chemicals, it is important to ensure that non-permeable barriers are used to adequately contain any leachate or waste material.
3. Temporarily divert, enclose or pump the water around the work site.
4. Perform a fish rescue of the isolated work area (contact KEPO for assistance).
5. Ensure the pump intake is screened with a fish screen and the point of discharge is located on a non-erodible surface immediately downstream of the work site to minimize disturbance to surrounding fish populations and habitats.
6. For works near or in lakes or larger water bodies, if it is not possible for you to fully isolate and divert flowing water from your work area due to water depth and volume, isolate your works with a silt curtain to keep silty water separate from clean water. Details about silt curtains are provided in Part 3 in the section entitled Sediment Control.
7. Contain any sediment-laden water generated during your works in an isolated work cell. Use a pump to draw sediment-laden water out of the work cell and discharge it to a level vegetated area at least 30 feet from creek bank where sediment can settle as the water infiltrates the ground.
8. Temporarily halt activities and secure site prior to and during heavy rains.

### *Work Site Maintenance*

Maintaining an organized and well-kept work area can also help to protect the environmental values of your work area.

1. Keep your work area organized and materials contained appropriately.
2. Ensure that all construction-related materials and debris are removed from your work area and site restoration measures are implemented as soon as possible following completion of work.
3. Store hydrocarbons or other hazardous substances in properly contained areas away from project sites. If storage of hydrocarbons or other hazardous materials is required on a project site, keep them away from water habitats and floodplains. Isolate and label the area to prevent accidents or leaks. Refueling should take place in this area and not near water.



### *Work Site Monitoring*

Monitoring the worksite is important to ensure that the Best Management Practices are being implemented properly and effectively.

1. It is recommended to assign an environmental liaison who is responsible for ensuring that the Best Management Practices are being implemented properly and that they are effectively protecting the surrounding environment. The environmental liaison is the person who should monitor the project site and have the following responsibilities:
  - Check on all the mitigation measures on a daily basis. Fix or adjust as needed.
  - Communicate regularly with the Environment Protection Office regarding the effectiveness of the mitigation measures.
  - Discuss concerns or problems with the Environment Protection Office regarding the mitigation measures in order to establish acceptable solutions.
  - Produce a brief end-of-project report outlining the mitigation measures, their effectiveness, and any recommendations for the future.

## ***Vehicle and Equipment Management***

The dirt that accumulates on vehicles and equipment may contain harmful contaminants such as de-icing compounds (road salts), vehicle fluids (oils and fuels), and brake dust. If washed into a storm drain, these contaminants make their way into the rivers, creeks and wetlands causing harm to fish, wildlife and vegetation. The following Best Management Practices should be followed for vehicle and equipment management.

### ***Vehicle and Equipment Selection and Operation***

1. Select machinery that is appropriate to the site characteristics and the environmental sensitivity of the area.
2. Do not operate the machinery in the water to minimize disturbance of the banks, shorelines and waterbeds. If absolutely necessary for safety reasons, isolate work area by creating a temporary by-pass.

### ***Vehicle and Equipment Cleaning and Maintenance***

1. Ensure that the machinery arrives on site clean and free of leaks, and maintain it in that condition.
2. Do not wash, refuel or service the machinery on a project site.
3. Vehicle and equipment maintenance should be carried out in a designated area with secondary containment, and away from storm drains.
4. Properly dispose of wastes generated by vehicle or equipment maintenance activities.
5. Vehicles and equipment should be washed in a designated and contained wash area that is sloped to facilitate the collection of wash water for treatment

Figure 15: Constructing a Designated Vehicle and Equipment Wash Area

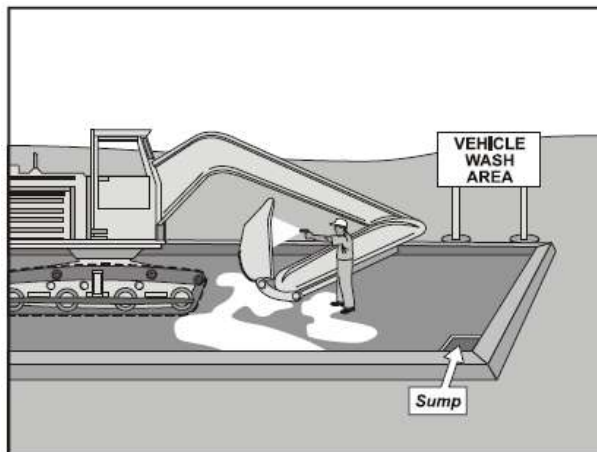

*Source of image: State of Hawaii. (2008)  
Construction Best Management Practices  
Field Manual.*

## ***Spill Prevention and Control***

1. Train employees on proper spill prevention and cleanup.
2. Develop an emergency plan to be implemented immediately in the event of a spill of harmful substances.

Figure 16: Preventing Spills and Planning for Emergencies

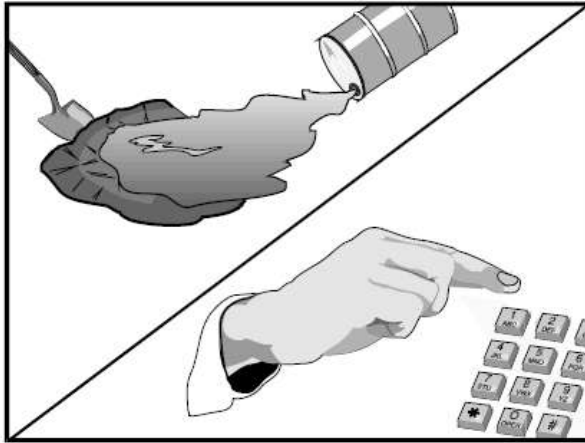

*Source of image: State of Hawaii. (2008)  
Construction Best Management Practices  
Field Manual.*

3. In the event of a spill, call the following numbers immediately:
  - Community Protection 450-632-0635
  - Environment Protection 450-635-0600
4. If the spill is of a serious nature and deemed to be dangerous or unmanageable, call the following numbers immediately:
  - Environment Canada's Emergency Hotline 514-283-2333
  - Kahnawà:ke Peace Keepers 450-632-6505
5. Communicate the emergency plan to all employees on a yearly basis, or at the start of each job.
6. Maintain an ample supply of cleanup materials to address spills on the ground or in water.
7. Clean spills promptly, using minimal water, and properly dispose of absorbent materials.

## ***Vegetation Management***

Vegetation includes small plants, grasses, shrubs and trees. The natural vegetation in our community provides many valuable functions. It filters our waters and cleans our air. The vegetation along our shorelines and creek banks is particularly important because it reduces erosion and sedimentation - both of which can lead to the destruction of fish spawning grounds and wildlife habitat.

The disturbance or removal of vegetation is often a necessary component of maintenance and development projects. However, with proper planning, care can be taken to reduce vegetation disturbance and minimize the impact on the area. Areas subject to vegetation disturbance should be restored as close as possible to their natural state, using species that are native to our area and appropriate to the habitat being disturbed.

### *Preserving Vegetation*

1. A vegetation management plan should be developed before the start of the job indicating access areas, tree removals, and protection areas. KEP can assist with the evaluation of high value species prior to the start of construction.
2. Minimize clearing of trees, shrubs and ground cover in natural areas. Where possible, maintain existing ground cover on shorelines and creek banks to maintain stable banks and maximize runoff filtration.
3. Contact the Kahnawà:ke Environment Protection Office prior to beginning works to identify any sensitive natural habitat areas or at risk species that should not be disturbed.
4. Before any work on the site is started, ensure that an inventory is made of the vegetation types and approximate quantity that will be disturbed. This information is needed for developing a site restoration plan.
5. Apply the “no-net-loss” principle for vegetation replacement. Any vegetation lost or impacted as a result of operations, maintenance or construction activities should be replaced with site-suitable native plant species on a 1:1 basis, preferably in the same location or general area that was disturbed.
6. Preserve vegetative cover for as long as possible. Schedule clearing activities immediately prior to works to minimize the length of time that soils within the disturbed area are exposed.
7. Maintain a continuous naturalized vegetated buffer along watercourse banks and shores. In Quebec<sup>4</sup> the minimum recommended width for a vegetated buffer is 10 meters from the high water mark. Wider vegetated buffers (15+ meters) are recommended for steep slopes (30% or more). Mark, flag or fence areas where vegetation is to be preserved. KEP staff can help recommend appropriate buffer widths depending on location.

### *Vegetation Removal*

1. Plant “rescue” can be used as a means of preserving existing vegetation and reducing remediation costs. Carefully remove small trees or shrubs for re-

---

<sup>4</sup> Politique de protection des rives, du littoral et des plaines inondables. Retrieved from [http://www2.publicationsduquebec.gouv.qc.ca/dynamicSearch/telecharge.php?type=3&file=/Q\\_2/Q2R35.htm](http://www2.publicationsduquebec.gouv.qc.ca/dynamicSearch/telecharge.php?type=3&file=/Q_2/Q2R35.htm)

- vegetation and store with the roots covered with mulch or loose soil. Keep roots moist (not wet) until ready to re-plant.
2. Ensure that your activities will not disturb nesting wildlife.
  3. Schedule any vegetation management activities that require the disturbance of soils to periods of dry weather, if possible.
  4. Do not remove vegetation on steep slopes. If this is unavoidable, appropriate slope stabilization techniques should be implemented (see Erosion Controls section).
  5. For creek maintenance activities, only remove the trees or branches that are posing a danger, causing obstacles to fish passage, or affecting the creek flow. Leave some fallen trees and rocks in place for wildlife shelter. Conserve trees and shrubs that are healthy and well-rooted in order to prevent bank erosion. If tree cutting is necessary, the tree roots should be left in place to continue to stabilize the bank.
  6. Collect landscape refuse (i.e., leaves and organic material) and place or dispose of in a manner that will prevent it from entering gutters, catch basins and watercourses.
  7. To minimize streambed disturbance, any trees being removed should not be felled across a watercourse or left below the ordinary high water mark unless specified in a work design.

### *Invasive Plant Species*

1. Remove invasive plant species from creek banks and shorelines. A list and photographs of invasive plant species that may be found in our community is included in Appendix B.
2. To reduce re-seeding or infection of other areas, collected invasive plants should either be burned using safe and controlled burning practices, or bagged and sent to a landfill.
3. In order to prevent or reduce re-establishment of invasive plants, re-vegetate as soon as possible with plants, shrubs and trees that are native to our area. A list of plants suitable for bank or shoreline re-vegetation is included in Appendix A in the *Répertoire des végétaux recommandés pour la végétalisation des bandes riveraines du Québec*.

## ***Fill Management***

Many construction projects involve digging and stockpiling of soil, gravel or debris. Kahnawà:ke has an unfortunate history of contaminated materials entering our environment and as a consequence there are many soils of unknown environmental quality. Soils might also be impacted by leaking aboveground or underground storage tanks, accidental spills of hazardous substances, or air pollution deposition from nearby industries or high-traffic areas. It is important that these materials are managed to ensure that they do not enter water habitats and have minimal impact on the surrounding environment.

1. During project planning and before materials are excavated from a site, estimate the amount of fill that will need to be moved to another site. This should be communicated to the Landfill Department as soon as possible in order to identify appropriate receptor sites, carry out the necessary inspections and reports, and obtain the required approvals. This proactive planning will eliminate costly delays during the project, and avoid fill being placed in inappropriate or environmentally sensitive areas.
2. If fill materials will be moved to another location, sampling and lab analysis should be carried out to determine if any contamination is present. It is highly recommended to sample the soils before they are excavated in order to isolate any contamination that may be present in the area. This will reduce disposal costs, if contamination is found. Follow the requirements in the Landfill Policy and Procedures for Clean Soil (2013) (Appendix E) to determine the parameters to be analyzed, and ensure that the appropriate communication is carried out with the Landfill Department.
3. Ensure that an impermeable membrane (plastic, tarp, geotextile, etc.) is available on-site in the event that contamination is known or suspected (ex. oily sheen, odor, area of suspect, etc.) in the excavated material.
4. Areas of known or suspected contamination includes, but is not limited to:
  - Known contaminated sites and adjacent properties
  - Areas adjacent to transportation corridors
  - Properties with past or present dumping, scrap car storage, garages, gas stations, snow dumping and their adjacent lots
5. Place any contaminated material (known or suspected) on an impermeable membrane at a distance greater than 30 feet from water habitats. Cover the piles with another impermeable membrane and stake or weigh it down to prevent contamination from entering the water or seeping into the surrounding soil.
6. Regularly inspect stockpiles for erosion and stabilize as necessary. Ensure stockpile covers are providing adequate protection from wind and rain.



Figure 17: Impermeable Membrane Under and Over Excavated Fill



*Source of image: State of Hawaii. (2008) Construction Best Management Practices Field Manual.*

7. Communicate with the Kahawai:ke Environment Protection Office regarding all incidents of contaminated fill. In some instances, material demonstrating contamination between B and C Criteria may be re-used under an impermeable surface in the community, if approved by the Kahawai:ke Environment Protection Office. Dispose of contaminated material above C Criteria outside the territory at a licensed facility.
8. If the soils will be backfilled on the same site, sampling is not required unless contamination is obvious (strong odor, oily sheen, etc.).
9. For materials that are stockpiled temporarily to be backfilled on the same site, ensure that they are placed on stable land well above the high water mark in a manner that prevents them from entering any watercourse. A minimum distance of 30 feet from the bank of any watercourse is recommended.
10. If the material is to be stockpiled on site for more than one week, cover it with an impermeable membrane or install a silt fence around it to further protect the surrounding environment.
11. Separate and preserve clean topsoil from the site for re-vegetation efforts and cover with a membrane to prevent runoff into any nearby water habitats.
12. Clean fill should be surrounded by a sediment fence and seeded with a native grass mix if not to be used within thirty days.
13. On-site erosion can be reduced by excavating on an as-needed basis rather than clearing the whole site at the beginning of the job.

### ***Erosion Control***

Soil erosion is a common problem resulting from construction projects. Healthy aquatic habitat is dependent on stable river and creek banks that are vegetated with appropriate native plant species. Without this vegetation to hold the soil in place, erosion occurs into

the water causing the destruction of fish and wildlife habitat. Eroded soil can accumulate in watercourses, clog culverts, destroy fish spawning grounds, nursery & feeding habitat, and make the habitat unfavorable for a wide variety of species. Once disturbed and if left un-checked, an eroded area is subject to ever-increasing levels of erosion. However, soil erosion can be prevented by planning for and implementing erosion control measures.

The following Best Management Practices should be implemented to prevent and control erosion on a project site:

### *Manage Construction Activities*

1. Maintain the site and surrounding area free of sediment that could be washed into the storm drains or directly into a watercourse.
  - Manage fill as described in the Fill Management section
  - Use street sweeping as needed.
  - Protect storm drain inlets with, filter mats or catch basin liners to filter sediment from curbside run-off before it enters the storm sewer. Inspect and clean filters regularly, particularly after a rain event.

### *Stabilize the Soil Using Mulching and Mats*

Although it is preferable to minimize the area to be disturbed and protect the natural vegetation, sometimes disturbance is inevitable during development or maintenance activities near water. In such instances, the soil of disturbed slopes should be stabilized as soon as possible to prevent erosion and sedimentation in the water.

1. If disturbance occurred or is required on a creek bank or shoreline, the soil can be stabilized temporarily by spreading and securing mulch, or applying a mat.
  - Mulch materials can include loose straw, shredded shrubs and trees, or wood chips. This technique should only be used on shallow slopes above the water line.
  - For steep slopes, tack, pin, or stake netting or jute over the mulch to hold it in place.
  - Erosion control mats can also be used to stabilize the bank, including natural mats such as jute and straw matting, or synthetic mats such as glass fiber matting or mulch netting
2. It is important to emphasize that these stabilization techniques are temporary measures and the soil should be re-vegetated as soon as possible with local species of grass, trees, shrubs or ground cover on a 1:1 basis. A list of plants suitable for bank or shoreline re-vegetation is included in Appendix A in the *Répertoire des végétaux recommandés pour la végétalisation des bandes riveraines du Québec*. Some erosion control mats already contain seed mix and

are therefore recommended to increase the speed of revegetation. Hydroseeding can also be considered.

Figure 18: Mulching Slopes with Loose Straw to Reduce Erosion



Figure 19: Using Coir Mats to Protect Exposed Areas Prior to Re-vegetation



3. A vegetated buffer strip on and adjacent to the creek banks and shorelines should be preserved or re-planted to maintain a stable slope and prevent erosion. As described in the Vegetation Management section, in Quebec the minimum recommended width for a vegetated buffer is 10 meters from the high water mark. Wider vegetated buffers (15+ meters) are recommended for steep slopes (30% or more).

## ***Sediment Control***

While preventing erosion is the best strategy for managing your construction site, any construction activity will inevitably generate sediment. Therefore, it is important to implement management controls to ensure sediment-laden storm water runoff does not enter watercourses or other off-site areas. The following techniques can be used for sediment control during your project:

- Silt fences
- Silt curtains
- Straw bale barriers
- Rock check dams

In order for these strategies to be effective, four key considerations are required; appropriateness, installation, maintenance, and removal.

The appropriateness of each measure above is explained in the relevant section below however in general, all of the above strategies above work primarily by holding back flow, thereby reducing flow velocity allowing sediment to settle out. They do NOT act as filters. With this in mind, consider how much water will be directed at the sediment control measure during a rain event. Silt fences and silt curtains should not be oriented perpendicular to flow in a watercourse because they will quickly be overcome by the force of the water and will fail. Straw bale barriers are useful in ditches and small intermittent creeks where only low flows are anticipated. Rock check dams are the sturdiest measure and can be used in intermittent creeks where occasional higher flows are possible. Note that any permanently flowing watercourse should be appropriately diverted (see Section on Work Site Isolation) rather than attempting to pool flow through the use of a sediment control measure.

Proper installation guidelines are provided below for each measure. If inappropriately installed, these measures will not prevent impacts to the environment. Inspection of these measures should occur weekly and after any rain event with repairs made as soon as identified. Maintenance should also include careful removal and disposal of excess sediment build-up to prevent failure.

These measures are intended to be used together as part of a comprehensive strategy for sediment control. Typically, a combination of two or more of the below measures is necessary to provide adequate sediment protection.

Removal should occur once the site has regenerated. Removal is very important as these sediment controls can often impact wildlife if left in place indefinitely.

### ***Silt Fence***

A silt fence is a sediment barrier made of geotextile filter fabric attached to supporting posts to intercept runoff from the project site. Silt fence should be installed around the work site along the edge of the disturbed work area with focus on areas with lower elevations and adjacent to sensitive habitats such as watercourses, wetlands and forests.

When installed correctly, the silt fence traps water running off the work site, allowing it to infiltrate into the ground and capturing the sediment.

**Silt Fence Installation:**

- In both cases above, the silt fence posts should be driven at least 14 inches into the ground and the filter fabric should be embedded at least 8 inches into the ground (see Figure 20).
- The ends of the silt curtain should be turned uphill.
- Inspect weekly during dry periods and daily during and after rainfall.
- Repair or replace damaged areas of silt curtain.
- Remove accumulated sediment when depth reaches 1/3 of the barrier height.

*Silt Curtain*

A silt curtain is also a geotextile barrier but it contains a weighted bottom and a float on the top. The purpose is to isolate a section of a watercourse so that work can be completed within the isolated area while preventing sediment from being dispersed downstream. This strategy is typically used in large watercourses where it is impractical to divert the flow around the work site. In our community, there use should be limited to work along the St. Lawrence River and within the Recreational Bay. Care must be taken when removing the silt curtain to prevent captured sediment from escaping.

**Silt Curtain Installation:**

- Silt curtain installation should be undertaken by an experienced contractor.
- The curtain must be anchored along the shore.
- The curtain must not obstruct the main flow of the channel, rather it is used to isolate a work site along the bank of the watercourse only.
- Care must be taken to ensure that the curtain does not get tangled when deployed
- More installation details can be found in Figure 21.
- Careful removal of the silt curtain is very important to prevent resuspension of the accumulated sediment. Refer to manufacturer's instructions for removal.

Figure 20: Silt Fence Installation

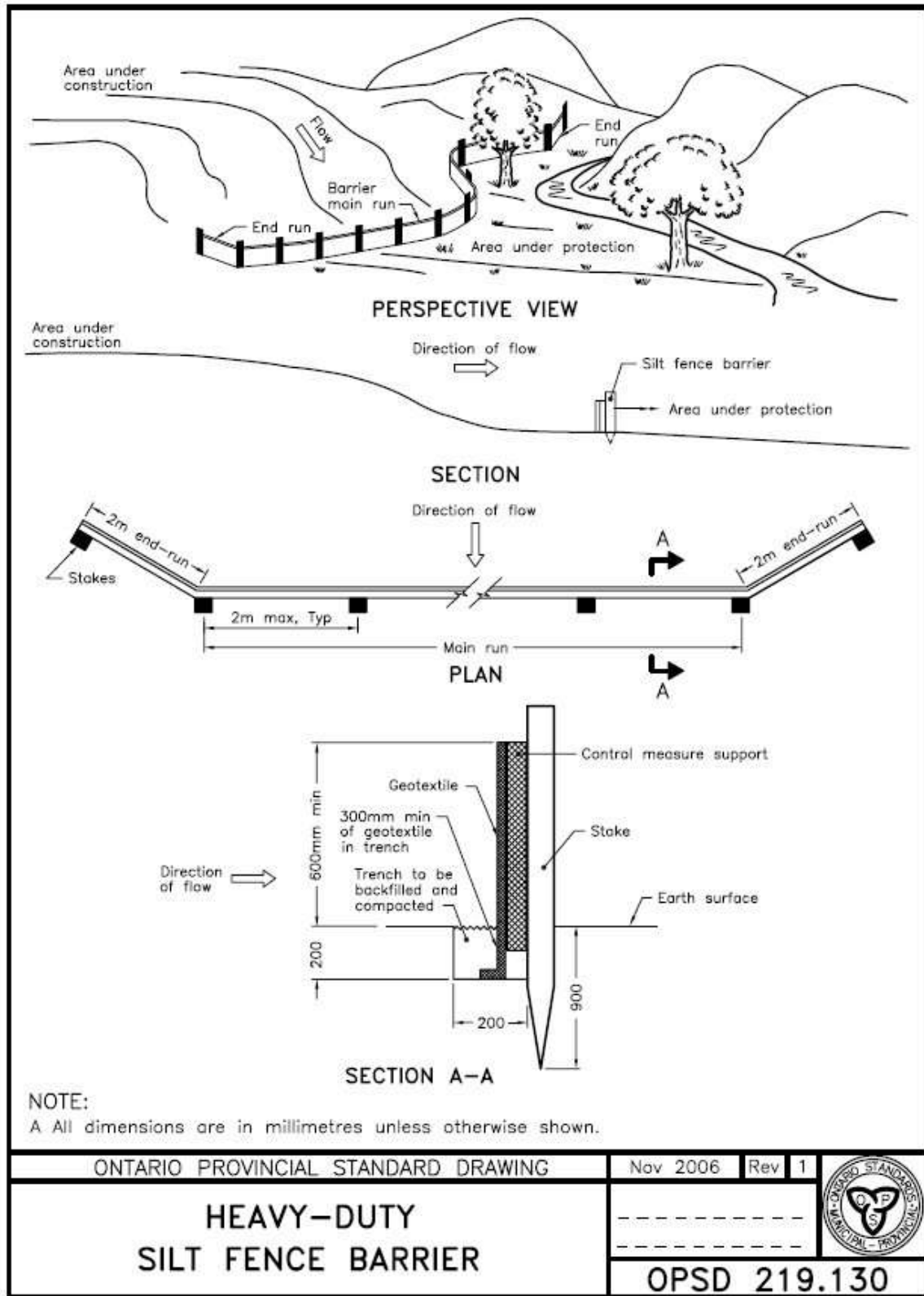
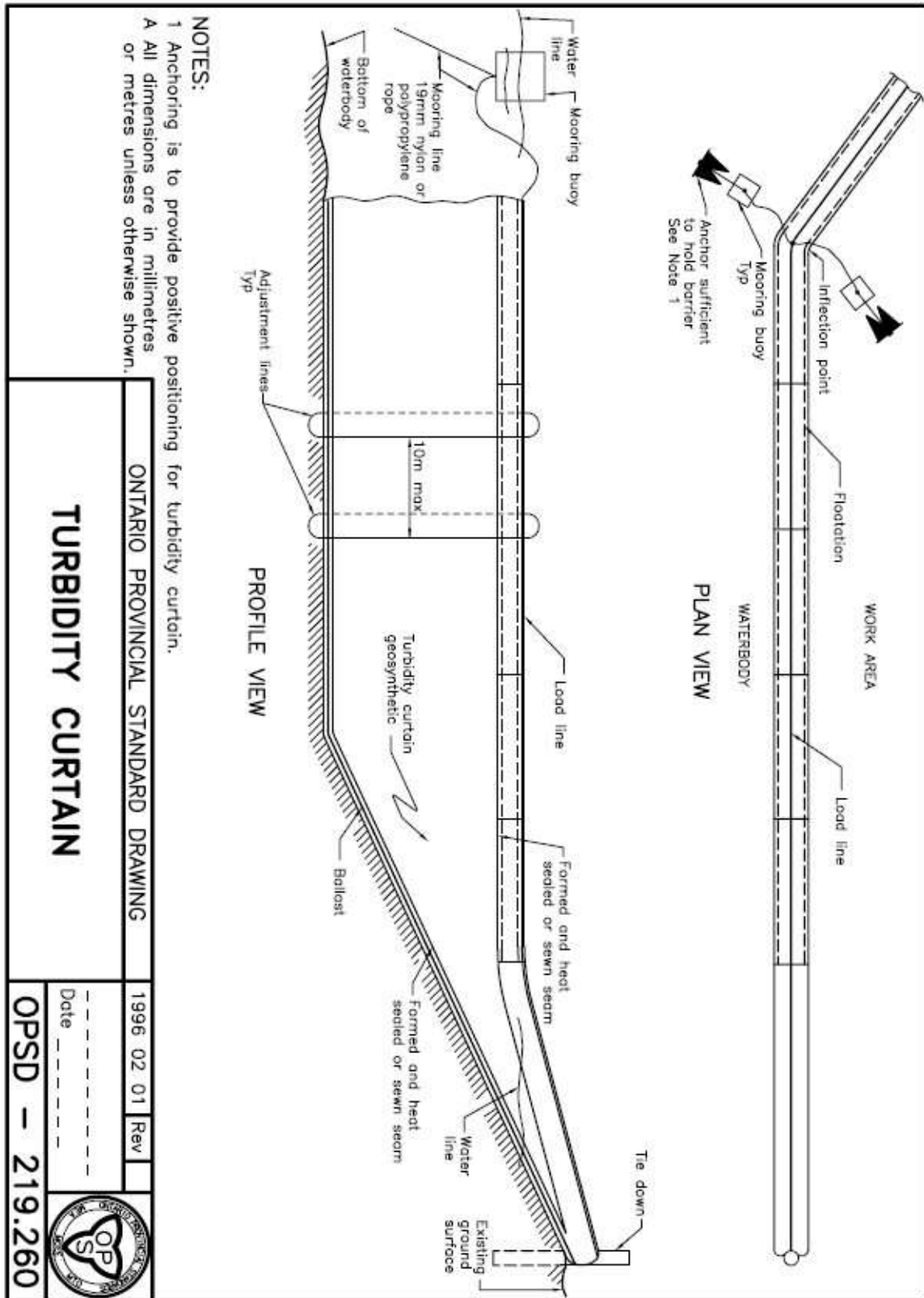

Figure 21: Silt Curtain Installation



NOTES:  
 1 Anchoring is to provide positive positioning for turbidity curtain.  
 A All dimensions are in millimetres or metres unless otherwise shown.

ONTARIO PROVINCIAL STANDARD DRAWING		1996 02 01	Rev
<b>TURBIDITY CURTAIN</b>		Date	
		OPSD - 219.260	



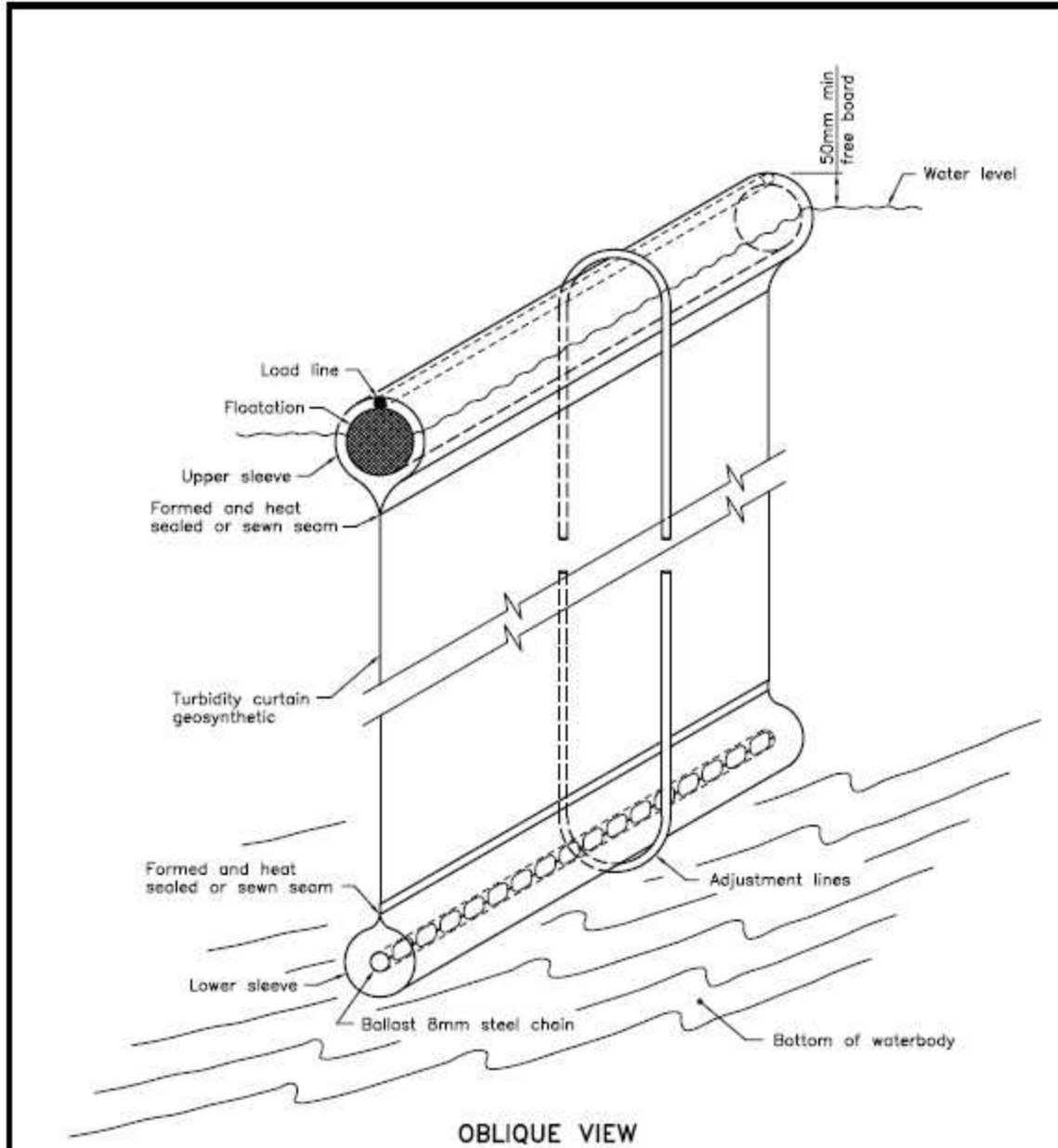

**NOTES:**

A. All dimensions are in millimeters.

ONTARIO PROVINCIAL STANDARD DRAWING		Nov 2006	Rev 1	
<b>TURBIDITY CURTAIN</b> SEAM DETAIL		-----		
		-----		
		<b>OPSD 219.261</b>		

Source of image: State of Hawaii. (2008) Construction Best Management Practices Field Manual.



### *Straw Bale Barriers*

Straw bale barriers are a simple and inexpensive sediment control technique. They employ a similar principle to the sediment fence by slowing water down to allow sediment deposition but they also filter water through the straw. Straw bale barriers are sturdier than silt fencing and therefore can be used across man-made ditches. Proper installation is very important to ensure straw bales remain in place during rain events. Barriers should be spaced every 25 m across the work site to ensure adequate sediment removal occurs.

#### Straw Bale Barrier Installation:

- A 4 inch deep trench should be dug to accommodate the straw bale barrier.
- The straw bale barrier should be staked at least 8 inches into the soil on either side of the bales or through the center of the bales to hold them in place. Rebar is the most effective stake for this purpose, but wood stakes can also be used.
- The bales should be installed adjacent to each other leaving no gaps between the bales.
- Straw bales should extend at least one metre beyond the high water mark on either bank to prevent flanking.
- Inspect weekly during dry periods and daily during and after rainfall.
- Repair or replace damaged areas of the straw bale barrier.
- Remove accumulated sediment when depth reaches 1/3 of the barrier height.
- Upon completion of the work, sediment should be removed and remaining straw can be used as mulch to stabilize banks.

Figure 22: Straw Bale Barrier Installed Across a Ditch During High Flows

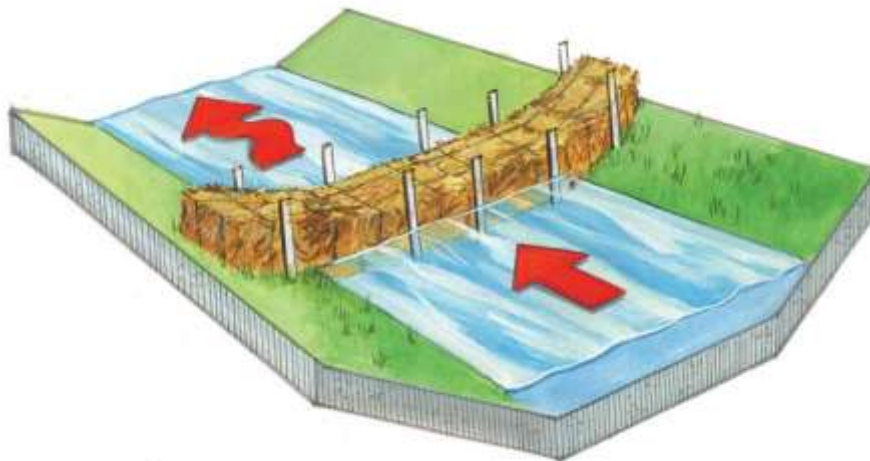

## *Rock Check Dams*

Rock check dams are sturdy sediment control measures intended for use in ditches and small watercourses where creek works are being undertaken. They consist of angular rock with impermeable layers of geotextile fabric intended to reduce the velocity of the water and prevent erosion from occurring in the creek. They also provide some ponding capacity allowing larger sediment to settle out behind the structure (Figure 23).

### Rock Check Dam Installation:

- Rock check dams contain three layers: A bottom layer of 50 mm diameter stone piled 0.5 m high; a middle layer of impermeable geotextile fabric; a top layer of 150 mm diameter stone extending from the swale invert to the top of the bottom layer. This layer should be a minimum of 200 mm thick and should contain a spillway in the middle to allow water to flow over the rock check dam.
- The rock should be piled with a 1.5:1 slope on the upstream side and a 4:1 slope on the downstream side.
- A series of check dams should be used in areas with steep slopes with the elevation of the top of the downstream dam equal to the toe of the previous dam.
- More installation details can be found in Figure 21.

Careful removal of the silt curtain is very important to prevent resuspension of the accumulated sediment. Refer to manufacturer's instructions for removal.

Figure 23: Typical Rock Check Dam Installation Details

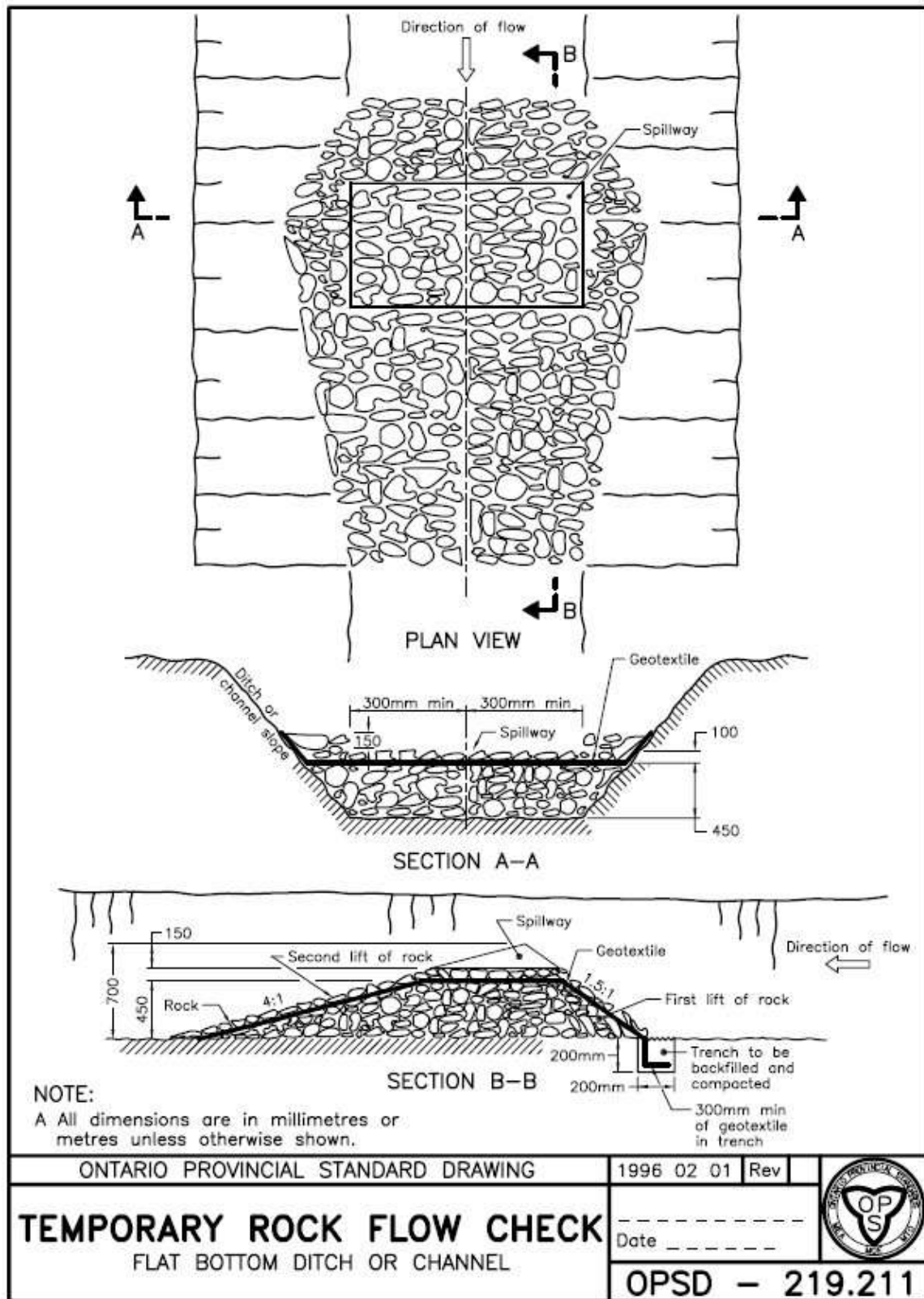

## *Mud mat*

Another strategy for reducing the movement of sediment off of a construction site is the installation of a mud mat. A mud mat is used at the entrance / exit of a construction site and removes sediment from equipment tires prior to entrance onto a public road. Mud mats should be considered for construction sites greater than one hectare in size.

### Mud Mat Installation:

- Mud mat should consist of a 450 mm thick rock pad underlain with a geotextile fabric.
- Pad should be a minimum of 10 m wide and 20 m long.
- The first 10 m from the public road should consist of 50 mm clear stone, with the remainder 150 mm clear stone.

## ***Site Restoration***

Remove any temporary access roads and stream crossings after the project is completed and remediate to pre-project conditions. Ensure that any vegetation lost or impacted as a result of operations, maintenance or construction activities is replaced with site-suitable native plant species as quickly as possible. A list of plants suitable for bank or shoreline re-vegetation is included in Appendix A in the *Répertoire des végétaux recommandés pour la végétalisation des bandes riveraines du Québec*.

In addition to purchasing native plant species from specialized nurseries, the following inexpensive, simple and effective techniques can be used for re-vegetation:

- Plant rescue
- Dormant cuttings and live staking
- Brush mats
- Grass rolls

### *Plant Rescue*

Rescuing plants from the project site or from another disturbed site is a simple and effective means of preserving existing vegetation and reducing remediation costs. Carefully remove small trees or shrubs for re-vegetation and store with the roots covered with mulch or loose soil. Keep roots moist (not wet) until ready to re-plant. If the plants will be stored longer than one growing season, they can be planted in the ground and transplanted when needed.

### *Dormant Cuttings and Live Staking*

Using cuttings of well-established native plants is another easy and inexpensive way to re-vegetate a disturbed area. Dormant cuttings can be planted directly into the ground using live staking. This technique is often used where single stem plantings will provide

adequate plant cover, slope stability and fish habitat. Live staking should be combined with other re-vegetation techniques.

Instructions for dormant cuttings and live staking:

- **Collect** dormant cuttings of willow in the Winter or early Spring, for Spring or early Summer planting. Dormant cuttings for Fall planting should be collected in early Fall after plants have gone dormant (at least 50% of the leaves have changed color or have dropped).
- **Select** branches 1/2 to 2 inches in diameter and at least 3 to 4 feet long. If necessary, branches can be cut to a shorter length at the time of installation. The potential for drying during storage is reduced when the cuttings are stored in longer pieces.
- **Tie** bundles of dormant cuttings with colored twine for ease in identification and carrying. Label each bundle with species, date collected, and number of cuttings.
- **Store** dormant cutting bundles. Frozen cuttings can be stored with a small amount of snow to help reduce drying. No water or burlap should be added to stored frozen cuttings.
- **Monitor** the condition of the cuttings regularly to detect problems such as drying, sprouting or mold.
- **Remove** from storage only the plant material required for each day, and place in water. Cuttings may be soaked in cool/cold water from 24-48 hours before planting to improve survivability.
- **Plant** dormant cuttings as soon as the soil has thawed and no later than July 1<sup>st</sup>, or plant in late Summer/Fall before the ground freezes.
- **Prepare** several live stakes from one dormant cutting. Cut stakes 10 to 18 inches long, 1/2 to 2 inches in diameter (slightly larger diameter cuttings will also work). Discard flower buds ("pussy willows"). Flower buds typically occur at the top 2/3 of a branch that was produced during the past growing season. At least one or two leaf buds (that are smaller than flower buds) must be present near the top of each live stake.
- **Select** planting sites carefully since live stakes require moist soils. The bottom 6 inches needs to be in permanently moist soils. If planted on drier slopes, survivability will decrease.
- **Use** rebar, 3/4 inch or less in diameter, to create a planting hole for longer stakes, particularly when planting in compact and gravelly soils. A shovel or hydraulic drill may also be used. Tightly pack the soil around the stake so that no air pockets remain.
- **Plant** stakes upright 1 to 3 feet on center. Stakes should be planted as vertically as possible, placing at least 3/4 of the stake below ground so that only one or two leaf buds are left exposed above the ground. The intent is to maximize the surface

area for rooting so a good root system can develop and support a healthy shoot system. Trim the stake if more than one or two buds, 1/4 of the stake, or 4 inches of the live stake is extending above the soil surface.

- **Water** to help remove air pockets and increase contact between the soil and surface of the live stake. Moist soil is needed during the period the live stake is rooting and becoming established, at least 4 to 6 weeks after planting. Topsoil is not required. Survival rates for drier sites may be increased if larger cuttings are used along with increased watering. Occasional deep watering is more effective and encourages deeper rooting than frequent light watering.

Figure 24: Harvesting Dormant Cuttings for Re-vegetation

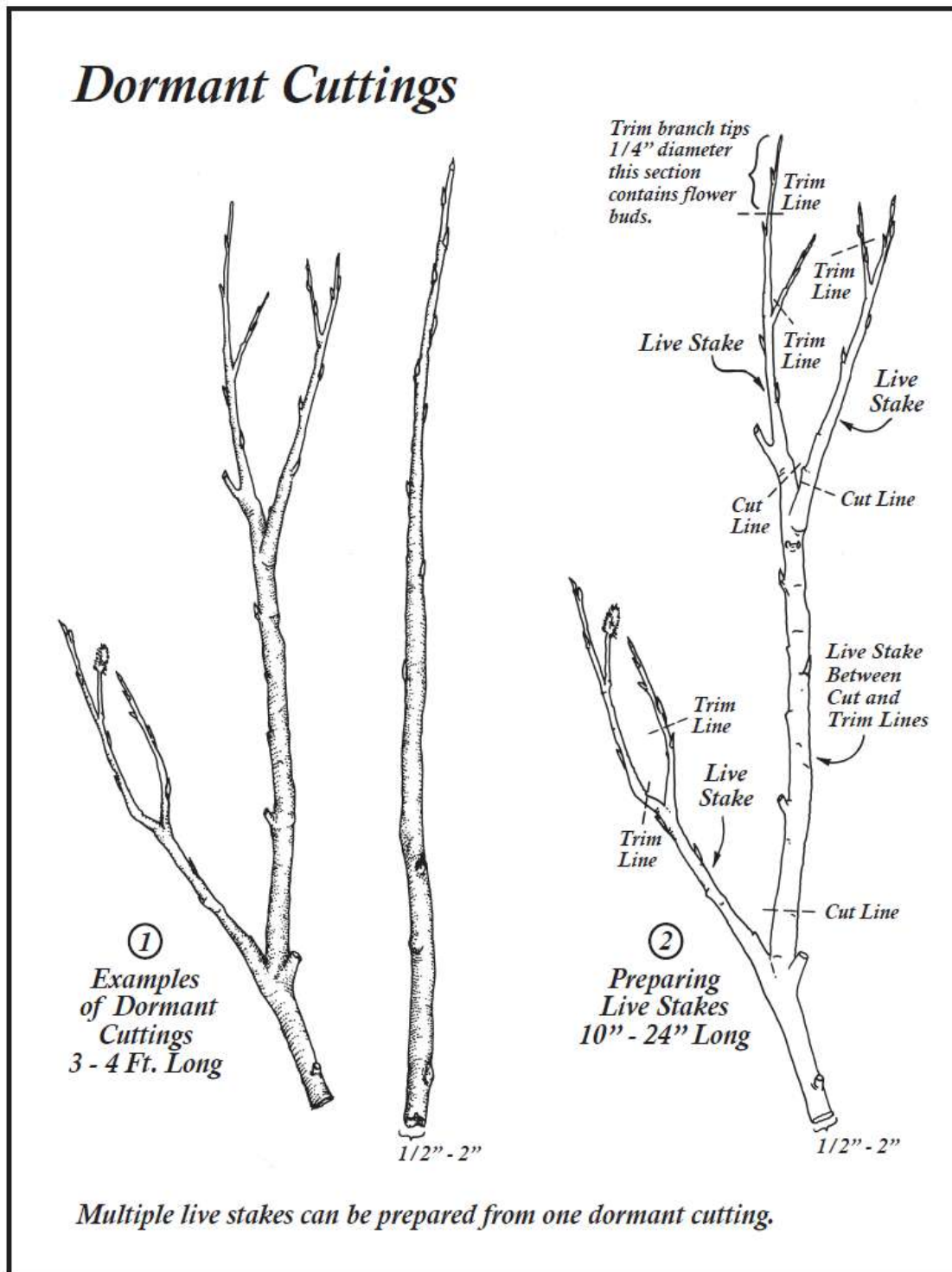
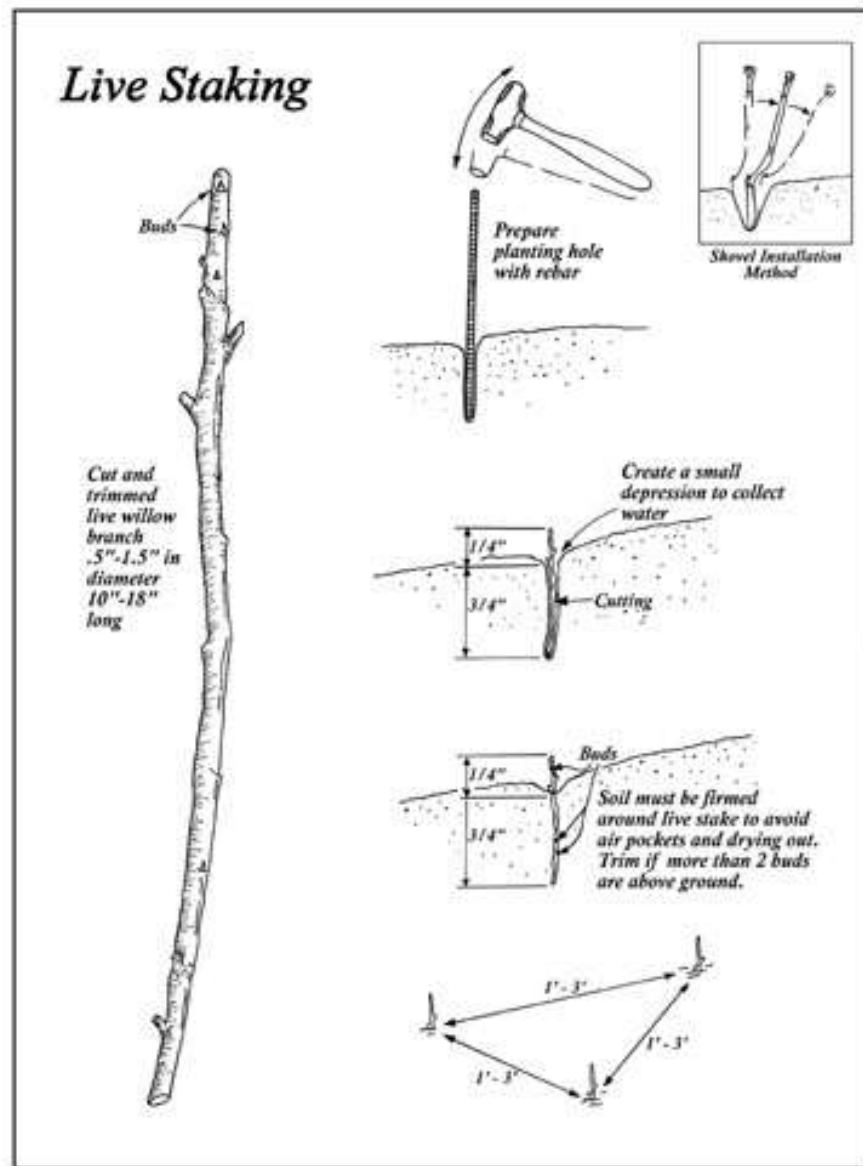

Figure 25: Planting Dormant Cuttings Using Live Staking



### *Brush Mats*

A brush mat is a re-vegetation technique that provides a protective vegetative covering to a slope as soon as it is installed. A brush mat can be constructed with dormant branches that will root and grow and is often combined with other re-vegetation and/or protection techniques such as seeding and live staking using dormant cuttings.

The brush mat will grow and provide plant cover, and the small pockets created by the overlapping branches will trap native seeds and provide an environment for germination



and growth. Eventually the plant growth on the stabilized streambank will provide fish habitat.

Figure 26: Brush Mat Re-Vegetation Technique



Instructions for brush mats:

- **Collect** a large quantity of branches. The availability of plant material should be carefully evaluated before including this technique in a re-vegetation design.
- **Scarify** the bank and deposit soil before installing the brush mat if the bank was stripped of vegetation and the soil is compacted.
- **Install** branches flat on the bank and perpendicular to the stream with branches slightly crisscrossed. The large end of the branch is placed at the toe of the slope. Add branches until the soil surface below the branches is covered. Brush mats can be installed over rooted plants and live stakes that are planted on a slope.
- **Stake** the mat in place. Place stakes on 3-foot centers, attach biodegradable twine or rope around each stake to form a crisscross pattern, and then drive the stakes into the substrate as deeply as possible pulling the branches tightly against the soil.
- **Add** a small amount of soil over the mat so that the lowest layer of branches is partially buried to encourage rooting.
- **Brush** mat lightly to compress the added soil; then add more soil if necessary. The completed compressed mat will be approximately 3-4 inches thick. If high water occurs before the brush mat becomes established, the topsoil on the lower portions of the mat may wash away. A light seeding of native grass may help prevent/reduce the loss of topsoil.

Figure 27: Brush Mat Installation Instructions

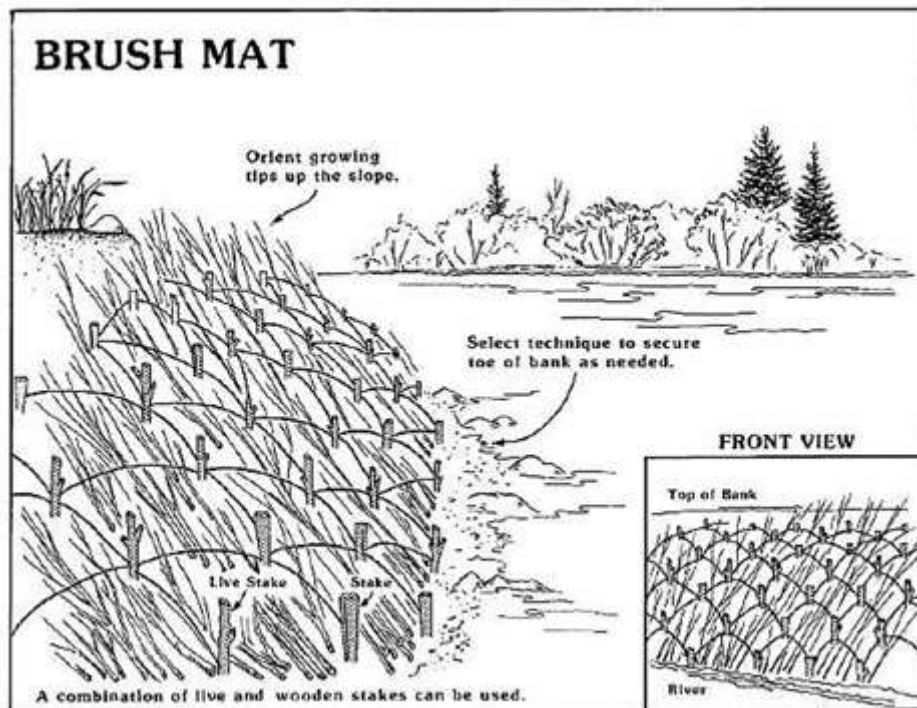

### Grass Rolls

Non-native species are not acceptable for planting on shorelines or creek banks; this includes most sods that are non-native grass species. Grass rolls are an effective technique to re-vegetate a bank with grasses while reducing erosion and sedimentation and providing some structural stability. When the grasses go dormant at the end of each growing season, their leaves hang over the stream bank and provide rearing habitat for fish.

#### Grass Roll Installation:

- **Select** native grass species for the grass roll. Bluejoint reedgrass, *Calamagrostis canadensis*, is the primary grass used for this technique and should be collected from sites away from stream banks. Beach wildrye, *Leymus mollis*, has also been used for stream bank plantings, and although it produces a strong rhizome it does not form the dense sod characteristic of Bluejoint. For wetland re-vegetation several sedge species are suitable including *Carex aquatilis*, and *Carex saxatilis*.

Figure 28: Re-vegetating a Creek Bank with Native Grasses

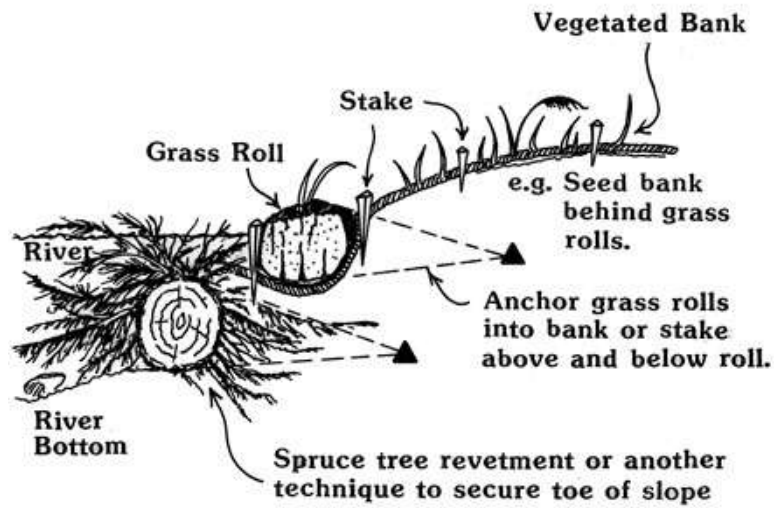

- **Construct** a grass roll by laying out a length of the biodegradable fabric; place clumps of sod tightly together in the middle of the fabric with shoots pointing up, in a sausage like structure.
- **Wrap** the sides of the biodegradable fabric over the sod clumps to make a sausage-like roll. Tie the roll every few inches with twine. Cut holes in the biodegradable fabric wrap to expose the sod shoots. Try to create the grass roll on-site so that the length of the roll(s) matches the length of the area being planted.
- **Dig** a shallow trench in which to install the grass roll along the ordinary high water (OHW). Grass rolls may also be constructed on-site in the trench.
- **Anchor** the grass roll securely into the bank. Earth anchors will be required for installations along streams and rivers. Stakes may be adequate for anchoring a grass roll in low-flow environments.
- **Re-vegetate** adjacent upslope areas as well. The ends of the grass roll need to transition smoothly into a stable streambank, undisturbed vegetation, or other re-vegetation technique.
- **Protect** grasses and sedges by elevated walkways or restrict access to the site because they are particularly sensitive to foot traffic.

Figure 29: Grass Roll Installation Instructions

## Constructing Grass Rolls Step-by-Step

- ① Dig trench and line with biodegradable fabric.

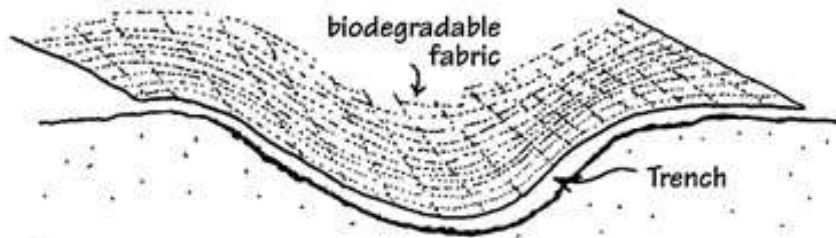

- ② Fill with grass clumps.

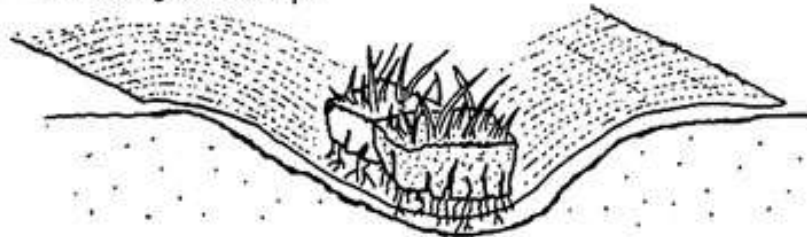

- ③ Fold biodegradable fabric over grass clumps so clumps are snug against each other.

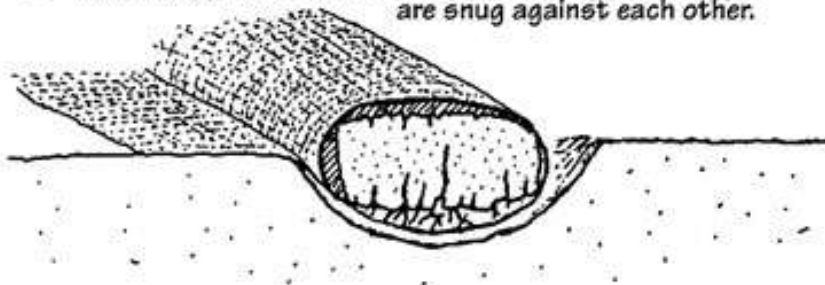

- ④ Pull shoots through wrap.

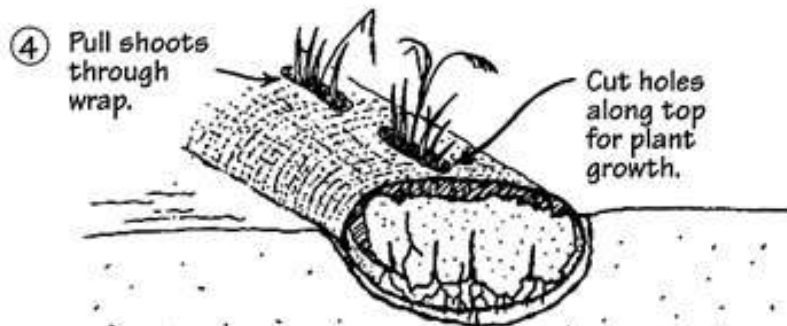

General re-vegetation instructions:

- Protect all landscaping materials from wind and rain by storing them under protective cover (i.e., tarps or plastic sheeting).
- Ensure that vegetation is planted well, at the right time of year, watered and otherwise maintained to a free-growing and established state.
- Monitor the re-vegetation site periodically during the current and next growing season to ensure effective establishment of the plants. Adjust the plan and re-plant as required, to ensure a stable slope with well-established vegetation.

### ***Beaver Control and Dam Removal<sup>5</sup>***

Beaver dams installed recently and obstructing fish passage are considered high impact and should be restored as soon as possible. The proposed restoration measure is beaver control and beaver dam removal. Controlling beavers or destroying their habitat by beaver dam removal is complicated greatly as the breaching of a beaver dam and the subsequent release of a large volume of water, silt and debris may cause undesirable damage while trying to solve the beaver problem. Indeed, removal of beaver dams can negatively affect fish and fish habitat by de-watering the upstream pond, stranding fish and releasing sediment and large volumes of water downstream. It is therefore important to exercise extreme caution when proceeding with dam removal due to the possibility of downstream flooding and damage and the re-entry of dam material into the watercourse.

Moreover, there is little value in removing a beaver dam without first managing the beaver population in the immediate area. Indeed, the breaching or removal of a beaver dam may not prevent future beaver activity in the area.

According to Fisheries and Oceans Canada, beaver dams need to be removed or breached periodically to protect, maintain or construct infrastructure or to avoid the flooding of private and public land. Removal is normally accomplished using hand tools, or equipment such as backhoes.

The best time to deal with beaver dam problems is during low-water periods (mainly August). As it is generally the lowest flow the creek will have throughout the year, this makes the release of water, debris, etc. much easier to work with. Beaver dam removal is preferably not done in the winter. This may result in losses of habitat for overwintering fish in the upstream pond and the discharge of water devoid of oxygen downstream.

The dam should be removed gradually to allow the water to release slowly and prevent sediment at the bottom of the pond from being released downstream. As the water levels drop in the upstream pond, increase the size of the opening to drain the pond to the

---

<sup>5</sup> AECOM. 2013. *Kahnawà:ke Fish and Fish Habitat. Final Report.*

desired level. The width of the breach opening of the beaver dam should not exceed the width of the original stream channel to prevent bank erosion and flooding of adjacent properties. When a series of dams is to be removed, this should be done from downstream to upstream in order to avoid severe flooding and damage to fish habitat.

While removing beaver dams, the existing trails, roads or cut lines should be used wherever possible to avoid disturbance to the riparian vegetation. Install effective sediment and erosion control measures before starting work to prevent the entry of sediment into the watercourse due to operations or other activities that disturb the bank during the removal project. If any fish become trapped in isolated pools or stranded in newly flooded areas, they should be relocated to the main channel of the watercourse.

Given that a beaver's dam collects all the debris that floats down the creek, garbage should be collected and disposed of prior to dam removal.

### ***Next Steps***

KEPO staff are available to discuss your construction project and ways of minimizing environmental impacts. Other techniques beyond those outlined here may also be feasible. Call KEPO at 450-635-0600 or email [environment.protection@mck.ca](mailto:environment.protection@mck.ca) to set-up an appointment or ask questions.

## References

- AECOM. (2013) *Kahnawà:ke Fish and Fish Habitat. Final Report.*
- British Columbia Ministry of Forests. (2002) *Forest Practices Code – Fish Stream Crossing Guidebook.* Retrieved from [www.for.gov.bc.ca/tasb/legregs/fpc/fpcguide/FishStreamCrossing/FSCGdBk.pdf](http://www.for.gov.bc.ca/tasb/legregs/fpc/fpcguide/FishStreamCrossing/FSCGdBk.pdf) [PDF - 1.94 MB - 74 pp]. Accessed January 2001.
- City of Winnipeg. (2005) *Best Practices Handbook for Activities In and Around the City's Waterways and Watercourses.*
- Fisheries and Oceans Canada (2009) *Measures to Protect Fish and Fish Habitat when Carrying Out a Temporary Stream Crossing.* Retrieved from <http://www.dfo-mpo.gc.ca/habitat/what-quoi/os-eo/qc/crossings-eng.asp>
- Fisheries and Oceans Canada. (2010) *Best Management Practice for the design and construction of permanent culverts less than 25 meters.* DFO Quebec Region.
- Government of Ontario. (2013) *Ontario Provincial Standards for Roads & Public Works.* Retrieved from <http://www.raqs.mto.gov.on.ca/techpubs/ops.nsf/OPSHomepage>
- Government of Quebec. (2013) *Politique de protection des rives, du littoral et des plaines inondables.* Retrieved from [http://www2.publicationsduquebec.gouv.qc.ca/dynamicSearch/telecharge.php?type=3&file=/Q\\_2/Q2R35.htm](http://www2.publicationsduquebec.gouv.qc.ca/dynamicSearch/telecharge.php?type=3&file=/Q_2/Q2R35.htm)
- Greater Golden Horseshoe Area Conservation Authorities. (2006) *Erosion & Sediment Control Guidelines for Urban Construction.* Available from <http://www.npca.ca/wp-content/uploads/ErosionandSedimentControl-Guidelines.pdf>
- Smolen, M.D., D.W. Miller, L.C. Wyatt, J. Lichthardt, and A.L. Lanier. (1988) *Erosion and Sediment Control Planning and Design Manual.* North Carolina Sedimentation Control Commission; North Carolina Department of Environment, Health, and Natural Resources; and Division of Land Resources Land Quality Section, Raleigh, NC.
- Societe de la faune et des parcs. (2003) *Fiche technique sur la protection de l'habitat du poisson: Les ponts et les ponceaux.*
- Société de la faune et des parcs. (2003) *Fiche technique sur la protection de l'habitat du poisson: Nettoyage léger des cours d'eau.*

Société de la faune et des parcs. (2003) *Fiche technique sur la protection de l'habitat du poisson: Stabilisation du milieu riverain.*

State of Hawaii. (2008) *Construction Best Management Practices Field Manual.*  
Department of Transportation and Highways Division.

Vermont Fish and Wildlife. (2010) *Vermont Stream Crossing Handbook.*

VDCR (Virginia Department of Conservation and Recreation). (1995) *Virginia Erosion & Sediment Control Field Manual.* 2nd ed. Virginia Department of Conservation and Recreation, Division of Soil and Water Conservation, Richmond, VA



## **Appendix A: Native Plant Species for Re-Vegetation of Creek Banks and Shorelines in Kahnawà:ke**

---



Répertoire des végétaux recommandés pour la  
**végétalisation**  
des bandes riveraines du Québec

**Agissez maintenant!**

# Une production de la **FIHOQ** et de **l'AQPP**

Sous la coordination de la Fédération interdisciplinaire de l'horticulture ornementale du Québec (FIHOQ), de concert avec l'Association québécoise des producteurs en pépinière (AQPP), ses associations affiliées, le Regroupement des organisations de bassin versant du Québec (ROBVQ) et le ministère du Développement durable, de l'Environnement et des Parcs (MDDEP), ce répertoire contient la liste des végétaux recommandés pour la végétalisation des bandes riveraines du Québec.

**La production de ce répertoire a été rendue possible grâce à la contribution financière du ministère de l'Agriculture, des Pêcheries et de l'Alimentation du Québec (MAPAQ), par l'intermédiaire du (*Programme d'appui financier aux associations de producteurs désignées*).**



## **Édition :**

- Fédération interdisciplinaire de l'horticulture ornementale du Québec (FIHOQ)

## **Réalisation et production :**

- Fédération interdisciplinaire de l'horticulture ornementale du Québec (FIHOQ)
- Association québécoise des producteurs en pépinière (AQPP)

## **Orientation, contenu et révision :**

- Membres des divers comités (voir page 26)

## **Validation des végétaux et de leurs caractéristiques :**

- Institut québécois du développement de l'horticulture ornementale (IQDHO)

## **Conception graphique, infographie et impression :**

- Horticolor

Ce répertoire est également disponible en version électronique, sur les sites suivants :

[www.fihoq.qc.ca](http://www.fihoq.qc.ca) et [www.aqpp.org](http://www.aqpp.org)

**ISBN 978-2-9810450-1-0**

Dépôt légal - Bibliothèque et Archives nationales du Québec, 2008

Dépôt légal - Bibliothèque et Archives Canada, 2008

# Répertoire des végétaux recommandés

pour la végétalisation des bandes riveraines du Québec

## Introduction

C'est reconnu, les végétaux sont essentiels à la vie. Ils sont tout aussi indispensables à la sauvegarde de nos cours d'eau, et à la protection de leur qualité...

### **un héritage vital !**

La promotion de la végétalisation des bandes riveraines est un geste simple qui permettra à l'industrie de l'horticulture ornementale de préserver cet héritage et de participer concrètement à l'amélioration de l'environnement, à la prévention de l'apparition d'algues bleu-vert, à la protection de la qualité de l'eau des lacs et des cours d'eau, et à la préservation de la faune et de la flore.

La production de ce répertoire de végétaux est le résultat de plusieurs mois de concertation et de consultation auprès d'intervenants et d'experts de l'industrie de l'horticulture ornementale, du ministère du Développement durable, de l'Environnement et des Parcs (MDDEP), de biologistes et de groupes environnementaux.

Cette liste de végétaux recommandés comprend des espèces indigènes, certains de leurs cultivars ainsi que des espèces naturalisées adaptées aux rives. Elle présente 19 caractéristiques qui vous aideront à mieux conseiller vos clients dans le choix de leurs plantes :

**«la bonne plante  
pour le bon endroit»**

Il est important de consulter cette liste pour éviter de choisir des espèces non recommandées, nuisibles ou envahissantes, toutes à proscrire. La liste sera en constante évolution. Il est possible que des modifications y soient apportées au fil du temps, en fonction des études et des évaluations. Consultez-la régulièrement.

Cette liste est également disponible sur les sites internet de la FIHOQ et de l'AQPP :  
[www.fihoq.qc.ca](http://www.fihoq.qc.ca) et [www.aqpp.org](http://www.aqpp.org)

# Arbres

Nom latin	Nom français	Nom anglais	Origine	Zone de rusticité	Exposition	Hauteur (mètre)	Largeur (mètre)	Humidité du sol	Type de sol	Localisation sur le talus
<i>Abies balsamea</i>	Sapin beaumier	Balsam Fir	Indigène	1		10-15	3-6	Moyenne à élevée	Graveleux, loam sableux à argileux	bas, milieu
<i>Acer pensylvanicum</i>	Érable de Pennsylvanie	Striped Maple	Indigène	2b		10-15	6-10	Moyenne à élevée	Loam sableux à loam argileux	Replat
<i>Acer rubrum</i>	Érable rouge	Red Maple	Indigène	3		9-20	15-22	Moyenne à élevée	Tout type de sol	Bas, Milieu
<i>Acer rubrum</i> et cultivars	Érable rouge	Red Maple	Cultivars d'indigène	3-5		9-20	3-22	Moyenne à élevée	Tout type de sol	Bas, Milieu
<i>Acer saccharinum</i>	Érable argenté	Silver Maple	Indigène	2b		20-30	20-30	Moyenne à élevée	Loameux à argileux	Bas, Milieu, Replat
<i>Acer saccharinum</i> et cultivars	Érable argenté	Silver Maple	Cultivars d'indigène	2b-4		18-30	8-30	Élevée	Loameux à argileux	Bas, Milieu, Replat
<i>Acer saccharum</i>	Érable à sucre	Sugar Maple	Indigène	4		20-30	15-20	Moyenne	Loam sableux à loam argileux	Replat
<i>Acer saccharum</i> et cultivars	Érable à sucre	Sugar Maple	Cultivars d'indigène	4-5		15-30	5-30	Moyenne	Loam sableux à loam argileux	Replat
<i>Betula alleghaniensis</i>	Bouleau jaune	Yellow Birch	Indigène	3b		15-22	10-15	Moyenne à élevée	Tout type de sol	Milieu, Replat
<i>Betula papyrifera</i>	Bouleau à papier	Paper Birch	Indigène	2		15-20	10-15	Moyenne à élevée	Sableux à loameux	Replat
<i>Betula papyrifera</i> 'Oenci'	Bouleau à papier 'Renaissance Oasis'	'Renaissance Oasis' Paper Birch	Cultivar d'indigène	3		13	5	Moyenne à élevée	Sableux à loameux	Replat
<i>Betula papyrifera</i> 'Renci'	Bouleau à papier 'Renaissance Reflexion'	'Renaissance Reflection' Paper Birch	Cultivar d'indigène	3		20	8	Moyenne à élevée	Sableux à loameux	Replat
<i>Betula papyrifera</i> 'Varen'	Bouleau à papier 'Prairie Dream'	'Prairie Dream' Paper Birch	Cultivar d'indigène	3		12	10	Moyenne à élevée	Sableux à loameux	Replat
<i>Betula populifolia</i>	Bouleau gris	Gray Birch	Indigène	3		10-15	6-10	Faible à élevée	Sableux à loam graveleux	Milieu, Replat
<i>Carya cordiformis</i>	Caryer cordiforme	Bitternut Hickory	Indigène	4		22-30	22-30	Faible à élevée	Loam sableux à argileux	Replat
<i>Crataegus punctata</i>	Aubépine ponctuée	Dotted Hawthorn	Indigène	5		7-10	7-10	Moyenne à faible	Sableux, loam graveleux à argileux	Milieu, Replat
<i>Crataegus chrysoarpa</i>	Aubépine à feuilles rondes	Round-Leaved Hawthorn	Indigène	4		4-6	4-6	Moyenne à faible	Sableux, loam graveleux à argileux	Milieu, Replat
<i>Crataegus submollis</i>	Aubépine subsoyeuse	Quebec Hawthorn	Indigène	4		5-8	5-8	Moyenne à faible	Sableux, loam graveleux à argileux	Milieu, Replat
<i>Fraxinus americana</i>	Frêne d'Amérique	White Ash	Indigène	3b		22-30	15-22	Moyenne	Sableux à loameux	Milieu, Replat
<i>Fraxinus americana</i> 'Jeffnor'	Frêne d'Amérique 'Autumn Blaze'	'Autumn Blaze' White Ash	Cultivar d'indigène	3		20	10	Moyenne	Sableux à loameux	Milieu, Replat
<i>Fraxinus americana</i> 'Autumn Purple'	Frêne d'Amérique 'Autumn Purple'	'Autumn Purple' White Ash	Cultivar d'indigène	4		15	9	Moyenne	Sableux à loameux	Milieu, Replat

Tolérance aux sels au niveau du sol	Type d'enracinement	Rôle de la plante				Type de croissance	Faune			Disponibilité en pépinière	COMMENTAIRES
		Stabilisation	Écran solaire	Protection contre l'érosion mineure des glaces	Brise-vent		Feuille noble	Nourriture	Végétaux épineux		
Non	Superficiel	🌲				Lente	🐜			Moyenne	Préférence pour les sols acides. Tolère les sols compacts. Sapin de Noël.
Non	Superficiel	🌲	🌲			Lente				Moyenne	Préférence pour les sols aérés et profonds. Aussi appelé: Bois d'original ou bois barré.
Non	Superficiel	🌲	🌲			Moyenne à rapide	👑	🐜		Très bonne	Préférence pour les sols acides. Tolère les sols compacts. Éviter les sols calcaires.
Non	Superficiel	🌲	🌲			Moyenne à rapide	👑			Très bonne	Préférence pour les sols acides. Tolère les sols compacts. Éviter les sols calcaires. Port variable selon les cultivars.
Modérée	Superficiel	🌲	🌲	🌲	🌲	Rapide		🐜		Très bonne	Supporte la pollution. Tolère les sols compacts. Racines envahissantes. Grand semencier, peut-être envahissant. Racines puissantes et bien développées.
Modérée	Superficiel	🌲	🌲	🌲	🌲	Lente à rapide	👑			Très bonne	Supporte la pollution. Tolère les sols compacts. Racines assez puissantes et envahissantes. Grand semencier, peut-être envahissant.
Non	Superficiel à modérément profond	🌲	🌲	🌲	🌲	Lente à moyenne	👑	🐜		Très bonne	Préférence pour les sols fertiles, profonds et bien drainés. Intolérance au compactage. Sensible à divers polluants.
Non	Superficiel à modérément profond	🌲	🌲	🌲	🌲	Lente à moyenne	👑			Bonne	Préférence pour les sols fertiles, profonds et bien drainés. Intolérance au compactage. Sensible à divers polluants. Port et dimension variable selon le cultivar.
Modérée	Modérément profond	🌲	🌲	🌲	🌲	Moyenne à rapide	👑	🐜		Faible	Préférence pour les sols fertiles et profonds. Intolérance au compactage. Port difforme en milieu ouvert.
Oui	Modérément profond	🌲		🌲		Moyenne à rapide		🐜		Très bonne	Préférence pour les sols acides. Intolérance au compactage du sol. Bonne capacité de captation du phosphore dans le sol. Sensible à la pollution urbaine.
Oui	Modérément profond	🌲		🌲		Moyenne	👑			Moyenne	Préférence pour les sols acides. Intolérance au compactage du sol. Port pyramidal.
Oui	Modérément profond	🌲		🌲		Rapide	👑			Bonne	Préférence pour les sols acides. Intolérance au compactage du sol. Port pyramidal.
Oui	Modérément profond	🌲		🌲			👑			Bonne	Préférence pour les sols acides. Intolérance au compactage du sol. Port semi-pyramidal à érigé-oval.
Oui	Superficiel	🌲	🌲	🌲	🌲	Moyenne à rapide		🐜		Faible	Sensible à la pollution.
Non	Pivotant	🌲	🌲			Lente à moyenne	👑	🐜		Faible	Préférence pour les sols fertiles et bien drainés. Sensible à la pollution. Produit des noix.
Non	Pivotant	🌲	🌲			Lente		🐜	✓	Faible	Tolère les sols très alcalins. Plante ignorée des cerfs.
Non	Pivotant	🌲	🌲			Lente		🐜	✓	Faible	Très épineux. Plante ignorée des cerfs.
Non	Pivotant	🌲	🌲			Lente		🐜	✓	Faible	Tolère les sols très alcalins. Plante ignorée des cerfs.
oui	Superficiel	🌲	🌲	🌲		Moyenne	👑	🐜		Très bonne	Préférence pour les sols bien drainés. Plante ignorée des cerfs. Grand semencier, peut être envahissant. Plante susceptible à l'agrite du frêne, évolution de ce ravageur à surveiller.
Modérée	Superficiel	🌲	🌲	🌲		Rapide	👑			Très bonne	Préférence pour les sols bien drainés. Plante ignorée des cerfs. Adapté aux conditions urbaines. Plante susceptible à l'agrite du frêne, évolution de ce ravageur à surveiller.
Oui	Profond	🌲	🌲	🌲		Moyenne	👑			Très bonne	Préférence pour les sols bien drainés. Plante ignorée des cerfs. Adapté aux conditions urbaines. Sélection mâle, donc sans fructification. Plante susceptible à l'agrite du frêne, évolution de ce ravageur à surveiller.

# Arbres

Nom latin	Nom français	Nom anglais	Origine	Zone de rusticité	Exposition	Hauteur (mètre)	Largeur (mètre)	Humidité du sol	Type de sol	Localisation sur le talus
<i>Fraxinus americana</i> 'Manitou'	Frêne d'Amérique 'Manitou'	'Manitou' White Ash	Cultivar d'indigène	3b		12	6	Moyenne	Sableux à loameux	Milieu, Replat
<i>Fraxinus americana</i> 'Northern Blaze'	Frêne d'Amérique 'Northern Blaze'	'Northern Blaze' White Ash	Cultivar d'indigène	3		15	8	Moyenne	Sableux à loameux	Milieu, Replat
<b><i>Fraxinus nigra</i></b>	Frêne noir	Black Ash	Indigène	2b		15-22	10-15	Élevée à moyenne	Loameux à argileux	Bas, Replat
<i>Fraxinus nigra</i> 'Fall Gold'	Frêne noir 'Fall Gold'	'Fall Gold' Black Ash	Cultivar d'indigène	3		15	7	Élevée à moyenne	Loameux à argileux	Bas, Replat
<i>Fraxinus nigra x mandshurica</i> 'Northern Gem'	Frêne 'Northern Gem'	'Northern Gem' Ash	Cultivar d'indigène	2b		11-15	7-8	Moyenne	Sableux à loameux	Milieu, Replat
<i>Fraxinus nigra x mandshurica</i> 'Northern Treasure'	Frêne 'Northern Treasure'	'Northern Treasure' Ash	Cultivar d'indigène	2		12	6	Moyenne	Sableux à loameux	Milieu, Replat
<b><i>Fraxinus pennsylvanica</i></b>	Frêne de Pennsylvanie	Red Ash	Indigène	2b		15-22	10-15	Moyenne à élevée	Tout type de sol	Bas, Milieu, Replat
<i>Fraxinus pennsylvanica</i> et cultivars	Frêne de Pennsylvanie	Red Ash	Cultivar d'indigène	2-4b		12-22	7-15	Moyenne à élevée	Tout type de sol	Bas, Milieu, Replat
<i>Fraxinus pennsylvanica</i> 'Rugby'	Frêne de Pennsylvanie 'Prairie Spire'	'Prairie Spire' Red Ash	Cultivar d'indigène	2b		15	4	Moyenne à élevée	Tout type de sol	Bas, Milieu, Replat
<b><i>Larix laricina</i></b>	Mélèze laricin	Eastern Larch	Indigène	1		15-20	10-15	Faible à élevée	Tout type de sol	Bas, Replat
<b><i>Picea glauca</i></b>	Épinette blanche	White Spruce	Indigène	1		15-22	6-10	Élevée à moyenne	Loameux à argileux	Replat
<b><i>Picea mariana</i></b>	Épinette noire	Black Spruce	Indigène	2b		15-22	6-10	Élevée	Tout type de sol	Bas, Replat
<b><i>Picea rubens</i></b>	Épinette rouge	Red Spruce	Indigène	4b		15-22	6-10	Élevée à moyenne	Tout type de sol	Replat
<b><i>Pinus resinosa</i></b>	Pin rouge	Red Pine	Indigène	2b		20-30	15-20	Moyenne	Sableux, graveleux à loam sableux	Replat
<b><i>Pinus strobus</i></b>	Pin blanc	Eastern White Pine	Indigène	2		22-30	15-22	Moyenne à faible	Loam sableux	Replat
<b><i>Populus balsamifera</i></b>	Peuplier baumier	Balsam Poplar	Indigène	1		15-22	6-10	Élevée à moyenne	Tout type de sol	Bas, Milieu, Replat
<b><i>Populus deltoides</i></b>	Peuplier deltoïdes	Eastern Cottonwood	Indigène	2b		20-30	20-30	Élevée à moyenne	Tout type de sol	Bas, Milieu, Replat
<i>Populus deltoides</i> 'Siouxland'	Peuplier à feuilles deltoïdes 'Siouxland'	'Siouxland' Eastern Cottonwood	Cultivar d'indigène	3		20	10	Élevée à moyenne	Tout type de sol	Bas, Milieu, Replat
<b><i>Populus grandidentata</i></b>	Peuplier à grandes dents	Large-Toothed Aspen	Indigène	2b		15-22	6-10	Élevée à moyenne	Tout type de sol	Bas, Milieu
<b><i>Populus tremuloides</i></b>	Peuplier faux-tremble	Trembling Aspen	Indigène	1b		10-15	6-10	Élevée à moyenne	Tout type de sol	Milieu, Replat
<b><i>Quercus macrocarpa</i></b>	Chêne à gros fruits	Bur Oak	Indigène	2b		22-30	22-30	Moyenne	Tout type de sol	Bas, Replat
<b><i>Quercus rubra</i></b>	Chêne rouge	Red Oak	Indigène	3		22-30	22-30	Moyenne	Loameux à argileux	Replat

Tolérance aux sels au niveau du sol	Type d'enracinement	Rôle de la plante				Type de croissance	Faune			Disponibilité en pépinière	COMMENTAIRES
		Stabilisation	Écran solaire	Protection contre l'érosion mineure des glaces	Brise-vent		Feuille noble	Nourriture	Végétaux épineux		
Oui	Profond	🌳	🌳	🌳		Moyenne	👑			Bonne	Préférence pour les sols bien drainés. Plante ignorée des cerfs. Bonne résistance à la pollution. Sélection sans fructification. Port colonnaire. Plante susceptible à l'agrite du frêne, évolution de ce ravageur à surveiller.
Oui	Superficiel	🌳	🌳	🌳		Rapide	👑			Bonne	Préférence pour les sols bien drainés. Plante ignorée des cerfs. Bonne résistance à la pollution. Plante susceptible à l'agrite du frêne, évolution de ce ravageur à surveiller.
Modérée	Superficiel	🌳	🌳			Moyenne		🐿		Faible	L'espèce la plus tolérante dans les sols mal drainés. Plante ignorée des cerfs. Plante susceptible à l'agrite du frêne, évolution de ce ravageur à surveiller.
Modérée	Superficiel	🌳	🌳			Moyenne	👑			Très bonne	L'espèce la plus tolérante dans les sols mal drainés. Plante ignorée des cerfs. Tolère la pollution urbaine.
Oui	Profond	🌳	🌳	🌳		Moyenne à rapide	👑			Faible	Préférence pour les sols profonds et humide. Plante susceptible à l'agrite du frêne, évolution de ce ravageur à surveiller.
Oui	Superficiel	🌳	🌳	🌳		Moyenne à rapide	👑			Bonne	Préférence pour les sols profonds et humide. Plante susceptible à l'agrite du frêne, évolution de ce ravageur à surveiller.
Modérée	Superficiel	🌳	🌳	🌳	🌳	Rapide		🐿		Très bonne	Tolère les sols compacts. Plante ignorée des cerfs. Plante susceptible à l'agrite du frêne, évolution de ce ravageur à surveiller.
Modérée	Superficiel à profond	🌳	🌳	🌳	🌳	Rapide	👑			Très bonne	Tolère les sols compacts. Plante ignorée des cerfs. Plante susceptible à l'agrite du frêne, évolution de ce ravageur à surveiller.
Modérée	Profond	🌳	🌳	🌳	🌳	Rapide	👑			Faible	Tolère les sols compacts. Plante ignorée des cerfs. Port érigé et étroit. Résistant à la pollution.
Oui	Superficiel		🌳	🌳		Rapide		🐿		Très bonne	À planter seulement dans les zones à faibles pentes. Tolère les sols détremés. Sensible à la pollution urbaine.
Non	Superficiel	🌳	🌳		🌳	Lente à moyenne		🐿		Très bonne	Préférence pour les sols frais et bien drainés. Port régulier. Plante ignorée des cerfs.
Non	Superficiel		🌳			Lente		🐿		Moyenne	Préférence pour les sols organiques et acides. Tolère les sols compacts. Peut se marcotter naturellement. Plante ignorée des cerfs. Sensible aux conditions urbaines.
Non	Superficiel		🌳		🌳	Lente		🐿		Faible	Préférence pour les sols acides. Plante ignorée des cerfs.
Non	Latéral profond	🌳	🌳			Moyenne		🐿		Moyenne	Peu tolérant dans les sols détremés ou compact. Plante ignorée des cerfs. Peu tolérant à la pollution.
Non	Latéral profond		🌳		🌳	Moyenne		🐿		Bonne	Préférence pour les sols acides, fertiles et bien drainés. Intolérance au compactage. Plante ignorée des cerfs.
Modérée	Superficiel	🌳	🌳		🌳	Rapide		🐿		Faible	Tolère les sols compacts. Plante drageonnante. Plante ignorée des cerfs.
Oui	Superficiel	🌳	🌳		🌳	Rapide		🐿		Bonne	Un des arbres dont la croissance est la plus rapide. Tolère les conditions urbaines.
Oui	Superficiel	🌳	🌳		🌳	Rapide				Bonne	Un des arbres dont la croissance est la plus rapide. Sélection mâle, fructification absente.
Modérée	Superficiel		🌳		🌳	Rapide		🐿		Faible	Préférence pour les sols fertiles et acides.
Modérée	Superficiel		🌳			Rapide		🐿		Faible	Racines très drageonnante. Peut tolérer à la pollution.
Oui	Pivotant	🌳	🌳	🌳	🌳	Lente	👑	🐿		Très bonne	Préférences pour les sols frais et profonds. Tolère la pollution. Produit des noix comestibles.
Oui	Latéral profond	🌳	🌳	🌳	🌳	Moyenne	👑	🐿		Très bonne	Préférence pour les sols non calcaires et bien drainés. Transplantation difficile. Un des chênes dont la croissance est la plus rapide. Tolère les conditions urbaines.



# Arbres

Nom latin	Nom français	Nom anglais	Origine	Zone de rusticité	Exposition	Hauteur (mètre)	Largeur (mètre)	Humidité du sol	Type de sol	Localisation sur le talus
<i>Salix amygdaloides</i>	Saule à feuilles de pêcher	Peachleaf Willow	Indigène	3b		10-15	10-15	Élevée à moyenne	Tout type de sol	Bas, Replat
<i>Salix nigra</i>	Saule noir	Black Willow	Indigène	4		10-15	6-10	Élevée	Tout type de sol	Bas, Replat
<i>Sorbus americana</i>	Sorbier d'Amérique	American Mountain-Ash	Indigène	3		15-20	10-15	Moyenne	Loam sableux	Replat
<i>Sorbus decora</i>	Sorbier des montagnes	Showy Mountain-Ash	Indigène	2		6-10	6-10	Moyenne	Tout type de sol	Replat
<i>Thuja occidentalis</i>	Thuya occidental	Eastern Arborvitae	Indigène	2		15-20	10-15	Élevée à faible	Tout type de sol	Bas, Milieu, Replat
<i>Thuja occidentalis</i> et cultivars	Thuya occidental	Eastern Arborvitae	Cultivar d'indigène	2-4		2-20	10-15	Élevée à faible	Tout type de sol	Bas, Milieu, Replat
<i>Tilia americana</i>	Tilleul d'Amérique	American Linden	Indigène	2b		22-30	15-22	Moyenne	Loameux	Replat
<i>Tilia americana</i> et cultivars	Tilleul d'Amérique	American Linden	Cultivar d'indigène	2b-4b		15-30	8-22	Moyenne	Loameux	Replat
<i>Tilia americana</i> 'Nova'	Tilleul d'Amérique 'Nova'	'Nova' American Linden	Cultivar d'indigène	3		20	10	Moyenne	Loameux	Replat
<i>Tsuga canadensis</i>	Pruche du Canada	Eastern Hemlock	Indigène	4		22-30	10-15	Élevée à moyenne	Loameux	Bas, Milieu, Replat

## Outils de mise en marché

Mandaté par la **FIHOQ**,  
**Horticolor** a conçu un pictogramme d'identification  
pour les végétaux recommandés pour la végétalisation des bandes riveraines  
et a élaboré des outils de mise en marché  
que vous pouvez consulter à la *page 27* de ce répertoire.

Tolérance aux sels au niveau du sol	Type d'enracinement	Rôle de la plante				Type de croissance	Faune			Disponibilité en pépinière	COMMENTAIRES
		Stabilisation	Écran solaire	Protection contre l'érosion mineure des glaces	Brise-vent		Feuille noble	Nourriture	Végétaux épineux		
Oui	Superficiel					Rapide				Faible	Tolère les sols compacts.
	Superficiel					Rapide				Faible	Préférence pour les sols acides. Tolère les sols compacts. Racines envahissantes.
Modérée	Superficiel					Moyenne				Faible	Préférence pour les sols acides. Risque de brûlure bactérienne.
Modérée	Superficiel					Moyenne				Faible	Préférence pour les sols acides. Croissance en talle. Risque de brûlure bactérienne.
Modérée	Superficiel					Moyenne				Très bonne	Préférence pour les sols profonds et calcaires. Tolère les sols compacts ou lourds. À planter seulement dans les zones à faible pente. Aussi appelé: Cèdre du Canada.
Modérée	Superficiel					Lente à moyenne				Très bonne	Préférence pour les sols profonds et calcaires. Tolère les sols compacts ou lourds. À planter seulement dans les zones à faible pente. Rusticité et port variable selon les cultivars. Aussi appelé: Cèdre.
Non	Latéral profond					Moyenne				Très bonne	Préférence pour les sols fertiles et profonds. Intolérance au compactage. Tolère les conditions urbaines.
Non	Latéral profond					Moyenne				Très bonne	Préférence pour les sols fertiles et profonds. Intolérance au compactage. Tolère la pollution.
Non	Latéral profond					Moyenne				Très bonne	Préférence pour les sols fertiles et profonds. Intolérance au compactage. Tolère la pollution.
Non	Superficiel					Lente à moyenne				Moyenne	Préférence pour les sols acides et bien drainés. Intolérance au compactage. Ne tolère pas les endroits venteux. Implantation difficile en milieu ouvert.

## des végétaux recommandés

Le pictogramme et les outils sont la propriété de la **FIHOQ**.  
Les entreprises de l'industrie de l'horticulture ornementale peuvent utiliser le pictogramme ainsi que les outils de mise en marché après avoir signé une licence d'utilisation.

Pour obtenir des renseignements supplémentaires,  
pour obtenir votre licence d'utilisation  
ou pour commander vos outils de mise en marché,  
il suffit de communiquer avec la **FIHOQ** au **450-774-2228**.

# Arbustes et Vignes

Nom latin	Nom français	Nom anglais	Origine	Zone de rusticité	Exposition	Hauteur (mètre)	Largeur (mètre)	Humidité du sol	Type de sol	Localisation sur le talus
<i>Acer spicatum</i>	Érable à épis	Mountain Maple	Indigène	2a		6	4	Moyenne à élevée	Sableux à loameux	Milieu, Replat
<i>Alnus incana subsp. rugosa</i>	Aulne rugueux	Speckled Alder	Indigène	1a		6-10	6-10	Élevée	Graveleux à loameux	Bas, Milieu, Replat
<i>Alnus viridis subsp. crispa</i>	Aulne crispé	American Green Alder	Indigène	1a		2-3	1-1,5	Moyenne à élevée	Tout type de sol	Bas, Milieu, Replat
<i>Amelanchier canadensis</i>	Amélanchier du Canada	Shadlow Serviceberry	Indigène	4a		4-7	4,5-6	Moyenne	Sableux à loameux	Replat
<i>Amelanchier canadensis</i> et cultivars	Amélanchier du Canada	Shadlow Serviceberry	Cultivars d'indigène	4		1,8-7	2-5	Moyenne	Sableux à loameux	Replat
<i>Amelanchier fernaldii</i>	Amélanchier de Fernald	Fernald Serviceberry	Indigène	4		0,3-1	1	Faible	Sableux à loameux	Replat
<i>Amelanchier laevis</i>	Amélanchier glabre	Allegheny Serviceberry	Indigène	2b		6-8	5	Moyenne	Sableux à loameux	Replat
<i>Amelanchier sanguinea var. gaspensis</i>	Amélanchier sanguin	Roundleaf Serviceberry	Indigène	3		1	1	Moyenne	Sableux à loameux	Replat
<i>Amelanchier stolonifera</i>	Amélanchier stolonifère	Running Serviceberry	Indigène	3		1,2-1,8	1,2	Faible à moyenne	Sableux à loam argileux	Milieu, Replat
<i>Andromeda polifolia</i>	Andromède à feuilles de Polium	Northern Bog Rosemary	Indigène	2a		0,3-0,6	0,6-0,9	Moyenne à élevée	Sableux à loameux	Bas
<i>Andromeda polifolia</i> et cultivars	Andromède	Bog Rosemary	Cultivars d'indigène	2		0,4	0,6	Moyenne	Loam sableux	Bas
<i>Arctostaphylos uva-ursi</i>	Raisin d'ours	Bearberry	Indigène	2a		0,3	1,5	Faible à élevée	Sableux, loameux à argileux	Bas, Milieu, Replat
<i>Arctostaphylos uva-ursi</i> et cultivars	Raisin d'ours	Bearberry	Cultivars d'indigène	2		0,25	1	faible à moyenne	Sableux à loam sableux	Bas, Milieu, Replat
<i>Aronia melanocarpa</i>	Aronie noire	Black Chokeberry	Indigène	4a		1,5-2	1-1,5	moyenne à élevée	Tout type de sol	Bas, Milieu, Replat
<i>Aronia melanocarpa</i> et cultivars	Aronie noire	Black Chokeberry	Cultivars d'indigène	4		1-2	1,2-1,5	moyenne à élevée	Tout type de sol	Bas, Milieu, Replat
<i>Cephalanthus occidentalis</i>	Céphalanthé occidental	Buttonbush	Indigène	4a		1-3	3-4	Élevée	Tout type de sol	Bas
<i>Clematis ligusticifolia</i>	Clématite de Virginie	Virgin's Bower	Indigène	2		3-4	vigne	Moyenne à élevée	Loam argileux à loam sableux	Milieu, Replat
<i>Comptonia peregrina</i>	Comptonie voyageuse	Sweetfern	Indigène	2a		0,6-0,9	1,2-2,4	Faible à élevée	Sableux, graveleux	Milieu, Replat
<i>Cornus alternifolia</i>	Cornouiller à feuilles alternes	Pagoda Dogwood	Indigène	3b		3-5	2	Élevée	Loameux	Bas, Milieu
<i>Cornus alternifolia</i> et cultivars	Cornouiller à feuilles alternes	Pagoda Dogwood	Cultivars d'indigène	3		2,5-6	2-6	Élevée	Loameux	Bas, Milieu
<i>Cornus obliqua</i>	Cornouiller oblique	Narrowleaf Dogwood	Indigène	5		1,5-3	3	Moyenne à élevée	Loameux	Milieu, Replat
<i>Cornus racemosa</i>	Cornouiller à grappes	Gray Dogwood	Indigène	2b		3	3	Moyenne	Tout type de sol	Bas, Milieu, Replat

Tolérance aux sels au niveau du sol	Type d'enracinement	Rôle de la plante				Faune			COMMENTAIRES	
		Stabilisation	Écran solaire	Protection contre l'érosion mineure des glaces	Brise-vent	Type de croissance	Nourriture	Végétaux épineux		Disponibilité en pépinière
Modérée	Superficiel					Lente			Faible	Intolérance au compactage. Préférence pour les sols acides. Sensible à la pollution.
Modérée	Superficiel					Rapide			Moyenne	Préférence pour les sols riches et légèrement acides. Tolère les conditions marécageuses et les sols pauvres. Non flexible. Plante fixatrice d'azote. Syn.: <i>Alnus serrulata</i> .
Non	Superficiel					Rapide			Bonne	Tolère les sols acides, compacts et pauvres. Plante fixatrice d'azote.
Oui	Superficiel					Moyenne			Très bonne	Préférence pour les sols bien drainés et acides. Intolérance au compactage. Racines drageonnantes. Syn.: <i>A. arborea</i> .
Oui	Superficiel					Moyenne			Très bonne	Préférence pour les sols bien drainés et acides. Intolérance au compactage. Racines drageonnantes. Syn.: <i>A. arborea</i> .
Oui	Superficiel					Moyenne			Faible à nulle	Préférence pour les sols bien drainés et meubles. Plante protégée dans son milieu naturel.
Non	Superficiel					Moyenne			Faible à nulle	Préférence pour les sols bien drainés et meubles. Intolérance au compactage. Sensible à la pollution. Non flexible.
Oui	Superficiel					Moyenne			Faible à nulle	Préférence pour les sols bien drainés et meubles.
Oui	Superficiel					Moyenne			Faible à nulle	Tolère la sécheresse et les sols lourds. Racines drageonnantes.
Modérée	Superficiel					Lente			Très bonne	Préférence pour les sols bien drainés et acides. Racines drageonnantes. Contrôle l'érosion.
Non	Superficiel					Lente			Très bonne	Contrôle l'érosion.
Non	Superficiel					Moyenne			Très bonne	Préférence pour les sols acides. Contrôle l'érosion.
Non	Superficiel					Lente			Très bonne	Contrôle l'érosion.
Modérée	Superficiel					Lente			Très bonne	Préférence pour les sols tourbeux et acides. Racines drageonnantes.
Modérée	Superficiel					Lente			Très bonne	Préférence pour les sols tourbeux et acides. Racines drageonnantes.
Oui	Superficiel					Moyenne			Bonne	Intolérance au compactage. Plante fixatrice d'azote.
Non	Superficiel					Rapide			Très bonne	Plante grimpante ou rampante.
Modérée	Superficiel					Lente à moyenne			Bonne	Préférence pour les sols tourbeux, pauvres et acides. Plante colonisante. Contrôle l'érosion. Syn.: <i>C. aspleniifolia</i> .
Non	Superficiel					Lente			Bonne	Plante ignorée des cerfs. Plante fixatrice d'azote.
Non	Superficiel					Lente			Bonne	Plante ignorée des cerfs. Plante fixatrice d'azote.
Oui	Superficiel					Moyenne à rapide			Faible à nulle	Tolère les sols secs. Plante ignorée des cerfs.
Oui	Superficiel					Lente			Faible	Plante ignorée des cerfs. Syn.: <i>Cornus paniculata</i> .

# Arbustes et Vignes

Nom latin	Nom français	Nom anglais	Origine	Zone de rusticité	Exposition	Hauteur (mètre)	Largeur (mètre)	Humidité du sol	Type de sol	Localisation sur le talus
<i>Cornus rugosa</i>	Cornouiller rugueux	Roundleaf Dogwood	Indigène	3a		1,5	2	Moyenne à élevée	Tout type de sol	Milieu, Replat
<i>Cornus stolonifera</i>	Cornouiller stolonifère	Redosier Dogwood	Indigène	2a		2	3	Faible à élevée	Tout type de sol	Bas, Milieu, Replat
<i>Cornus stolonifera</i> et cultivars	Cornouiller stolonifère	Redosier Dogwood	Cultivars d'indigène	3-4		0,80-3	1,5-2	Élevée à moyenne	Loam argileux, loam sableux à argileux	Bas, Milieu, Replat
<i>Corylus cornuta</i>	Noisetier à long bec	Beaked Hazelnut	Indigène	3		1,2-2,4	1,2-2,4	Faible à moyenne	Tout type de sol	Bas, Milieu, Replat
<i>Crataegus flabellata</i>	Aubépine flabelliforme	Fanleaf Hawthorn	Indigène	5		5-6	5-6	Faible à moyenne	Loameux	Milieu, Replat
<i>Diervilla lonicera</i>	Dièreville chèvrefeuille	Bush Honeysuckle	Indigène	3a		0,9-1,2	0,9-1,2	Faible à moyenne	Sableux, graveleux	Milieu, Replat
<i>Hamamelis virginiana</i>	Hamamélis de Virginie	Common Witchhazel	Indigène	4b		5-7	5-6	Moyenne	Loameux	Milieu, Replat
<i>Ilex mucronata</i>	Némopanthé mucroné	Mountain Holly	Indigène	2		1-3	1-1,5	Élevée	Tout type de sol	Bas, Milieu, Replat
<i>Ilex verticillata</i>	Houx verticillé	Common Winterberry	Indigène	3b		1,8-3	1,8-3	Élevée	Loameux	Bas, Milieu, Replat
<i>Ilex verticillata</i> et cultivars	Houx verticillé	Winterberry	Cultivars d'indigène	3b		2	1,5	Élevée	Loameux	Bas, Milieu, Replat
<i>Juniperus communis</i>	Genévrier commun	Common Juniper	Indigène	3		1,5-3	2,5-3,6	Faible	Tout type de sol	Replat
<i>Juniperus communis</i> et cultivars	Genévrier commun	Common Juniper	Cultivars d'indigène	2b-4a		0,3-0,6	1,25-1,5	Faible	Graveleux	Replat
<i>Ledum groenlandicum</i>	Thé du Labrador	Labrador Tea	Indigène	1a		0,6-1,2	0,8-1,5	Élevée	Sableux	Bas, Milieu
<i>Ledum groenlandicum</i> 'Compactum'	Thé du Labrador 'Compactum'	'Compactum' Labrador Tea	Indigène	1a		0,3	0,8	Élevée	Sableux	Bas, Milieu
<i>Lonicera canadensis</i>	Chèvrefeuille du Canada	American Fly Honeysuckle	Indigène	3a		1-1,8	1-1,5	Moyenne à élevée	Tout type de sol	Bas, Milieu, Replat
<i>Lonicera canadensis</i> 'Marble King'	Chèvrefeuille du Canada 'Marble King'	'Marble King' American Fly Honeysuckle	Cultivars d'indigène	3		1-1,8	1-1,5	Moyenne à élevée	Tout type de sol	Bas, Milieu, Replat
<i>Lonicera dioica</i>	Chèvrefeuille dioïque	Mountain Honeysuckle	Indigène	2		0,80-3	2	Faible	Graveleux	Bas, Milieu, Replat
<i>Lonicera involucrata</i>	Chèvrefeuille involucre	Black Twinberry	Indigène	4b		1,3	1	Moyenne à élevée	Tout type de sol	Bas
<i>Lonicera oblongifolia</i>	Chèvrefeuille à feuilles oblongues	Swamp Fly Honeysuckle	Indigène	4		0,6-1,5	0,6-1,5	Moyenne à élevée	Tout type de sol	Bas, Milieu, Replat
<i>Myrica gale</i>	Myrique baumier	Sweet Gale	Indigène	2a		0,6-1,2	2	Élevée	Loameux	Bas
<i>Parthenocissus quinquefolia</i>	Vigne vierge	Virginia Creeper	Indigène	2		4-15	1	Moyenne	Tout type de sol	Milieu, Replat
<i>Parthenocissus quinquefolia</i> var. <i>engelmannii</i>	Vigne vierge d'Engelmann	Engelmann's Ivy	Cultivars d'indigène	2b		10	1,5	Moyenne	Tout type de sol	Milieu, Replat

Tolérance aux sels au niveau du sol	Type d'enracinement	Rôle de la plante				Faune			COMMENTAIRES	
		Stabilisation	Écran solaire	Protection contre l'érosion mineure des glaces	Brise-vent	Type de croissance	Nourriture	Végétaux épineux		Disponibilité en pépinière
Non	Superficiel					Moyenne			Faible	Plantes drageonnantes. Tolère les sols lourds. Plante ignorée des cerfs.
Oui	Superficiel					Rapide			Très bonne	Tolère les sols compacts. Plante drageonnante. Plante ignorée des cerfs. Excellent pour stabiliser les talus abrupts. Syn.: <i>Cornus sericea</i> .
Oui	Superficiel					Rapide			Très bonne	Tolère les sols compacts. Plante drageonnante. Plante ignorée des cerfs. Excellent pour stabiliser les talus abrupts. Syn.: <i>Cornus sericea</i> .
Non	Superficiel								Bonne	Préférence pour les sols bien drainés et acides. Plante ignorée des cerfs. Plante drageonnante pouvant être considérée comme envahissante.
Oui	Profond					Moyenne			Faible à nulle	Préférence pour les sols bien drainés. Tolérance à la sécheresse une fois établie. Tolère la pollution et les sols lourds ou alcalins. Plante ignorée des cerfs.
Oui	Superficiel					Rapide			Très bonne	Préférence pour les sols légèrement acides et bien drainés. Plante drageonnante mais non envahissante.
Oui	Superficiel					Lente à moyenne			Bonne	Plante fixatrice d'azote. Contrôle l'érosion.
	Superficiel					Rapide			Faible	Limité aux habitats marécageux et acides. Syn.: <i>Nemopanthus mucronatus</i> .
Non	Superficiel					Lente à moyenne			Très bonne	Préférence pour les sols acides. Tolère les sols lourds. Non flexible.
Non	Superficiel					Lente			Très bonne	Préférence pour les sols acides. Tolère les sols lourds. Non flexible.
Modérée	Superficiel					Lente			Bonne	Tolère les sols compacts. Non flexible. Plante ignorée des cerfs. Contrôle l'érosion.
Modérée	Superficiel					Lente			Très bonne	Non flexible. Plante ignorée des cerfs. Contrôle l'érosion.
Modérée	Superficiel					Lente			Faible	Préférence pour les sols tourbeux et acides. S'adapte aux conditions marécageuses. Contrôle l'érosion.
Modérée	Superficiel					Lente			Faible	Préférence pour les sols tourbeux et acides. S'adapte aux conditions marécageuses. Contrôle l'érosion.
Oui	Superficiel					Rapide			Faible	Préférence pour les sols bien drainés et fertiles.
Oui	Superficiel					Rapide			Faible	Préférence pour les sols bien drainés et fertiles. Feuillage panaché.
Oui	Superficiel					Rapide			Faible	Tolère la sécheresse. Plante grimpante ou rampante.
Oui	Superficiel					Rapide			Très bonne	
Oui	Superficiel					Rapide			Faible	Préférence pour les sols acides.
Modérée	Superficiel					Moyenne			Bonne	Préférence pour les sols acides et tourbeux. Tolère les sols pauvres et détrempés. Plante drageonnante. Contrôle l'érosion.
Modérée	Superficiel					Rapide			Très bonne	Intéressante pour la renaturalisation des murets. Plante grimpante ou rampante. Préférence pour les milieux secs et légèrement acides. Tolère les conditions venteuses et la pollution. Contrôle l'érosion. Peut être toxique.
Modérée	Superficiel					Rapide			Très bonne	Intéressante pour la renaturalisation des murets. Plante grimpante ou rampante. Préférence pour les milieux secs et légèrement acides. Tolère les conditions venteuses et la pollution. Contrôle l'érosion.

# Arbustes et Vignes

Nom latin	Nom français	Nom anglais	Origine	Zone de rusticité	Exposition	Hauteur (mètre)	Largeur (mètre)	Humidité du sol	Type de sol	Localisation sur le talus
<i>Physocarpus opulifolius</i>	Physocarpe à feuilles d'obier	Common Ninebark	Indigène	2b		1,5-3	2-3	Faible à élevée	Tout type de sol	Bas, Milieu, Replat
<i>Physocarpus opulifolius</i> et cultivars	Physocarpe à feuilles d'obier	Ninebark	Cultivars d'indigène	2b		1-3	1-2,5	Moyenne	Tout type de sol	Replat
<i>Potentilla fruticosa</i>	Potentille frutescente	Bush Cinquefoil	Indigène	2a		0,3-1,3	0,6-1,3	Moyenne	Tout type de sol	Bas, Milieu, Replat
<i>Potentilla fruticosa</i> et cultivars	Potentille frutescente	Bush Cinquefoil	Cultivars d'indigène	2-3		0,5-1,25	0,6-1,5	Faible à moyenne	Tout type de sol	Replat
<i>Prunus nigra</i>	Prunier noir	Canada Plum	Indigène	4		6-9	3-4,5	Moyenne	Tout type de sol	Milieu, Replat
<i>Prunus pumila</i> var. <i>depressa</i>	Cerisier des sables	Dwarf Sand Cherry	Indigène	3		0,3-0,4	2	Faible	Sableux, graveleux	Milieu, Replat
<i>Rhododendron canadense</i>	Rhododendron du Canada	Rhodora	Indigène	2		0,9-1,2	0,9-1	Moyenne à élevée	Loameux à loameux sableux	Milieu, Replat
<i>Rhus aromatica</i>	Sumac aromatique	Fragrant Sumac	Indigène	3		0,6-1,8	1,8-3	Faible à moyenne	Tout type de sol	Milieu, Replat
<i>Rhus aromatica</i> 'Grow-Low'	Sumac aromatique 'Grow-Low'	'Grow-Low' Fragrant Sumac	Cultivars d'indigène	3		0,6-0,8	1,5-3,0	Faible à moyenne	Sableux à loam sableux	Milieu, Replat
<i>Rhus typhina</i>	Sumac vinaigrier	Staghorn Sumac	Indigène	3a		4,5-7,6	4,5-9	Faible	Tout type de sol	Milieu, Replat
<i>Rhus typhina</i> et cultivars	Sumac vinaigrier	Staghorn Sumac	Cultivars d'indigène	3-4		1,75-2,5	1,75-2	Faible	Sableux, graveleux	Replat
<i>Rosa acicularis</i>	Rosier aciculaire	Prickly Wild Rose	Indigène	3		0,3-2	1,2-1,8	Faible à moyenne	Tout type de sol	Milieu, Replat
<i>Rosa blanda</i> var. <i>blanda</i>	Rosier inerme	Smooth Wild Rose	Indigène	2		1,5-2	1,2-1,5	Faible à moyenne	Tout type de sol	Milieu, Replat
<i>Rosa nitida</i>	Rosier brillant	Shining Rose	Indigène	2		0,6-1	0,6-1	Moyenne	Sableux, loam sableux à graveleux	Milieu, Replat
<i>Rosa rubiginosa</i>	Églantier	Common Sweet Brier	Naturalisée	5		3	3	Moyenne à faible	Tout type de sol	Milieu, Replat
<i>Rubus allegheniensis</i>	Ronce alléghanienne	Alleghaney Blackberry	Indigène	3		1-2	1-2	Faible à moyenne	Loam argileux à graveleux	Milieu, Replat
<i>Rubus occidentalis</i>	Ronce occidentale	Black Raspberry	Indigène	3		1-1,8	1,8 et +	Moyenne	Loameux	Milieu, Replat
<i>Rubus odoratus</i>	Ronce odorante	Flowering Raspberry	Indigène	4a		1,5-2	1,5-2	Moyenne à élevée	Sableux	Bas, Milieu
<i>Salix bebbiana</i>	Saule de Bebb	Bebb's Willow	Indigène	2		5-6	10	Moyenne à élevée	Tout type de sol	Bas
<i>Salix discolor</i>	Saule discoloré	Pussy Willow	Indigène	2		6-8	4-5	Moyenne à élevée	Tout type de sol	Bas, Milieu, Replat
<i>Salix eriocephala</i>	Saule à tête laineuse	Cottony Willow	Indigène	3		2-4	2	Moyenne à élevée	Tout type de sol	Bas
<i>Salix exigua</i> subsp. <i>interior</i>	Saule de l'intérieur	Sandbar Willow	Indigène	2		1-6	1,8-3	Moyenne à élevée	Tout type de sol	Bas, Milieu, Replat
<i>Salix lucida</i>	Saule brillant	Shining Willow	Indigène	1		3-8	3-8	Moyenne à élevée	Tout type de sol	Bas

Tolérance aux sels au niveau du sol	Type d'enracinement	Rôle de la plante				Faune			COMMENTAIRES	
		Stabilisation	Écran solaire	Protection contre l'érosion mineure des glaces	Brise-vent	Type de croissance	Nourriture	Végétaux épineux		Disponibilité en pépinière
Oui	Superficiel					Moyenne			Très bonne	Tolère les sols compacts et les conditions de sécheresse. Éviter les sols détrempés. Éviter les cultivars ornementaux sur les rives du fleuve St-Laurent.
Non	Superficiel					Rapide			Très bonne	Éviter les cultivars ornementaux sur les rives du fleuve St-Laurent.
Oui	Superficiel					Moyenne			Très bonne	Préférence pour les sols bien drainés et fertiles. Plante ignorée des cerfs.
Oui	Superficiel					Moyenne			Très bonne	Préférence pour les sols bien drainés et fertiles. Plante ignorée des cerfs.
Modérée	Intermédiaire					Lente		✓	Faible	Préférence pour les sols bien drainés. Sensible au nodule noir.
Modérée	Superficiel					Lente à moyenne			Faible	Préférence pour les sols bien drainés. Intéressante pour la renaturalisation des murets. Éviter les espèces exotiques. Tolère les conditions de sécheresse une fois établie et les pieds dans l'eau temporairement.
Non	Superficiel					Moyenne			Faible	Préférence pour les sols tourbeux et acides.
Modérée	Superficiel					Lente à moyenne			Moyenne	Préférence pour les sols acides et bien drainés. Plante qui tend à drageonner. Couvre-sol. Contrôle l'érosion.
Non	Superficiel					Lente			Moyenne	Port plus compact que l'espèce. Préférence pour les sols acides et bien drainés. Contrôle l'érosion.
Modérée	Superficiel					Lente à moyenne			Très bonne	Préférence pour les sols bien drainés. Plante drageonnante et appropriée que dans les grands espaces. Non flexible.
Modérée	Superficiel					Rapide			Très bonne	Préférence pour les sols bien drainés. Plante drageonnante et appropriée que dans les grands espaces. Non flexible.
Oui	Superficiel					Rapide		✓	Faible	Préférence pour les sols légèrement acides et bien drainés. Tolère les sols lourds.
Oui	Superficiel					Rapide		✓	Faible	Préférence pour les sols bien drainés. Tolère les sols lourds. Bonne résistance aux insectes et aux maladies. Plante drageonnante.
Oui	Superficiel					Rapide		✓	Faible	Tolère les inondations passagères. Plante drageonnante. Couvre-sol. Bonne résistance aux insectes et aux maladies.
Oui	Superficiel					Moyenne		✓	Faible	Plante drageonnante. Tolère les sols alcalins. Syn.: <i>Rosa eglanteria</i> .
Non	Superficiel					Moyenne		✓	Faible	Préférence pour les sols riches et bien drainés. Peut devenir envahissante.
Non	Superficiel					Rapide		✓	Faible	Préférence pour les sols riches et bien drainés.
Non	Superficiel					Rapide			Moyenne	Préférence pour les sols bien drainés. Plante drageonnante.
Oui	Superficiel					Rapide			Faible	Préférence pour les sols lourds et humides.
Modérée	Superficiel					Rapide			Faible	Préférence pour les sols lourds et humides. Contrôle l'érosion du sol. Adapté pour les conditions maritimes. Flexible.
Non	Superficiel					Moyenne			Faible	Préférence pour les sols organiques et humides. Peut subir une immersion prolongée. Syn.: <i>Salix rigida</i> , <i>S. rigida</i> var. <i>cordata</i> .
Modérée	Superficiel					Rapide			Faible	Préférence pour les sols lourds et humides. Contrôle l'érosion du sol. Flexible. Syn.: <i>Salix interior</i> .
Modérée	Superficiel					Rapide			Faible	Préférence pour les sols profonds et lourds. Tolère les forts vents.



























# Arbustes et Vignes

Nom latin	Nom français	Nom anglais	Origine	Zone de rusticité	Exposition	Hauteur (mètre)	Largeur (mètre)	Humidité du sol	Type de sol	Localisation sur le talus
<i>Salix pellita</i>	Saule satiné	Satiny Willow	Indigène	2		2-3	1,5-2	Moyenne à élevée	Tout type de sol	Bas
<i>Salix petiolaris</i>	Saule à long pétiole	Slender Willow	Indigène	2		1-3	1-2	Moyenne à élevée	Tout type de sol	Bas
<i>Salix sericea</i>	Saule soyeux	Silky Willow	Indigène	5		3,6	2-4	Moyenne à élevée	Tout type de sol	Bas
<i>Sambucus canadensis</i>	Sureau du Canada	American Elder	Indigène	3a		1,5-3,6	1,5-2	Faible à élevée	Tout type de sol	Bas, Milieu, Replat
<i>Sambucus canadensis</i> et cultivars	Sureau du Canada	American Elder ou Elderberry	Cultivars d'indigène	3		2-3	1,5-2,5	Élevée à moyenne	Tout type de sol	Bas, Milieu, Replat
<i>Sambucus pubens</i>	Sureau pubescent	Scarlet Elder	Indigène	5		2-4	1,2-1,5	Élevée	Tout type de sol	Bas, Milieu, Replat
<i>Shepherdia canadensis</i>	Shépherdie du Canada	Russet Buffaloberry	Indigène	2a		1-2,5	1-2,4	Faible	Sableux	Bas, Milieu, Replat
<i>Shepherdia canadensis</i> et cultivars	Shépherdie du Canada	Russet Buffaloberry	Cultivars d'indigène	2		1-2,5	1-2,4	Faible	Sableux	Bas, Milieu, Replat
<i>Spiraea latifolia</i>	Spirée à larges feuilles	Large-Leaved Meadowsweet	Indigène	4		0,6-1,5	0,6-1,5	Moyenne	Tout type de sol	Bas, Milieu, Replat
<i>Spiraea tomentosa</i>	Spirée tomenteuse	Hardhack	Indigène	3		0,9-1,5	0,9-1,5	Faible à moyenne	Tout type de sol sauf argileux	Bas, Milieu, Replat
<i>Symphoricarpos albus</i>	Symphorine blanche	Common Snowberry	Indigène	2a		1-1,5	1-1,5	Faible à élevée	Tout type de sol	Bas, Milieu, Replat
<i>Vaccinium angustifolium</i>	Bleuet à feuilles étroites	Lowbush Blueberry	Indigène	2a		0,15-0,6	0,6	Faible à moyenne	Sableux	Bas
<i>Vaccinium macrocarpon</i>	Canneberge à gros fruits	American Cranberry	Indigène	3		0,05-0,3	0,3-1,8	Moyenne à élevée	Sableux à loameux	Replat
<i>Vaccinium myrtilloides</i>	Bleuet fausse-myrrille	Velvetleaf Blueberry	Indigène	3		0,1-0,6	0,1-0,6	Élevée	Loameux	Bas
<i>Viburnum cassinoides</i>	Viorne cassinoïde	Northern Wild Raisin	Indigène	2a		1,5-2	1,5-3	Faible à élevée	Loameux	Bas, Milieu, Replat
<i>Viburnum lantanoides</i>	Viorne à feuilles d'aulne	Hobblebush	Indigène	3a		2	2	Moyenne	Sableux	Milieu, Replat
<i>Viburnum lentago</i>	Viorne flexible	Nannyberry	Indigène	2a		4,5-5,4	1,8-3	Faible à élevée	Tout type de sol	Milieu, Replat
<i>Viburnum trilobum</i>	Viorne trilobée	American Cranberrybush Viburnum	Indigène	2a		2,5-3,6	2,5-3,6	Moyenne	Loameux	Milieu, Replat
<i>Viburnum trilobum</i> et cultivars	Viorne trilobée	Cranberrybush Viburnum	Cultivars d'indigène	2		1,5-3	1,5-3	moyenne à élevée	Loam argileux, loam sableux à sableux	Milieu, Replat
<i>Viburnum rafinesquianum</i>	Viorne de Rafinesque	Downy Viburnum	Indigène	3		1,2-1,8	1,2-1,8	Faible à moyenne	Tout type de sol	Replat
<i>Vitis riparia</i>	Vigne des rivages	Riverbank Grape	Indigène	2		1,5-6	1	Moyenne à élevée	Tout type de sol	Bas, Milieu, Replat
<i>Zanthoxylum americanum</i>	Clavaiier d'Amérique	Toothache Tree	Indigène	3		3-7	3-7	Faible à moyenne	Graveleux	Bas, Milieu, Replat

Tolérance aux sels au niveau du sol	Type d'enracinement	Rôle de la plante				Faune		Disponibilité en pépinière	COMMENTAIRES
		Stabilisation	Écran solaire	Protection contre l'érosion mineure des glaces	Brise-vent	Type de croissance	Nourriture		
Modérée	Superficiel	🌲				Rapide	🐜		Préférence pour les sols lourds et humides.
Modérée	Superficiel	🌲				Rapide	🐜		Préférence pour les sols lourds et humides. Flexible. Tolérance pour les sols pauvres et une sécheresse temporaire une fois établie.
Modérée	Superficiel					Rapide	🐜		Très bonne
Modérée	Superficiel	🌲				Rapide	🐜		Bonne
Modérée	Superficiel	🌲				Rapide			Très bonne
Modérée	Superficiel	🌲				Rapide	🐜		Moyenne
Oui	Intermédiaire	🌲				Lente			Très bonne
Oui	Intermédiaire	🌲				Lente			Moyenne
Non	Superficiel	🌲				Moyenne	🐜		Moyenne
Non	Superficiel	🌲				Moyenne	🐜		Moyenne
Oui	Superficiel	🌲				Rapide	🐜		Très bonne
Non	Superficiel					Lente			Moyenne
Oui	Superficiel				🌲	Lente	🐜		Faible
Non	Superficiel					Lente	🐜		Faible
Non	Superficiel	🌲			🌲	Lente	🐜		Faible
Modérée	Superficiel	🌲				Moyenne	🐜		Très bonne
Non	Superficiel	🌲	🌲		🌲	Rapide	🐜		Moyenne
Modérée	Superficiel	🌲			🌲	Moyenne	🐜		Moyenne
Modérée	Superficiel	🌲			🌲	Lente à moyenne	🐜		Très bonne
Non	Superficiel				🌲	Moyenne	🐜		Faible
Modérée	Superficiel	🌲	🌲			Moyenne	🐜		Moyenne
	Superficiel	🌲	🌲			Rapide	✓		Faible à nulle

# Vivaces

Nom latin	Nom français	Nom anglais	Origine	Zone de rusticité	Exposition	Hauteur (centimètre)	Largeur (centimètre)	Humidité du sol	Type de sol	Localisation sur le talus
<i>Anemone canadensis</i>	Anémone du Canada	Canadian Anemone	Indigène	3		40	30	Moyenne à élevée	Loameux à loam argileux	Bas, Milieu, Replat
<i>Apios americana</i>	Apios d'Amérique	American Ground Nut	Indigène	4		150	60	Élevée	Tout type de sol	Bas
<i>Apocynum cannabinum</i>	Apocyn chanvrin	Indian Hemp	Indigène	3		80	50	Moyenne à élevée	Tout type de sol	Bas, Milieu
<i>Calla palustris</i>	Calla des marais	Water Arum	Indigène	2		20	20	Très élevée	Loameux à argileux	Bas
<i>Caltha palustris</i>	Populage des marais	Marsh Marigold	Indigène	3		30	25	Très élevée	Loameux à loam argileux	Bas
<i>Caltha palustris</i> 'Flore Pleno'	Populage des marais 'Flore Pleno'	'Flore Pleno' Marsh Marigold	Cultivar d'indigène	3		40	40	Très élevée	Loameux à loam argileux	Bas
<i>Caltha palustris</i> 'Polypetala'	Populage des marais 'Polypetala'	'Polypetala' Marsh Marigold	Cultivar d'indigène	3		45-60	30-60	Très élevée	Loameux à loam argileux	Bas
<i>Caltha palustris var. alba</i>	Populage des marais	Marsh Marigold	Variété d'indigène	3		25-30	20-25	Très élevée	Loameux à loam argileux	Bas
<i>Chelone glabra</i>	Galane glabre	Turtlehead	Indigène	3		90	60	Moyenne à élevée	Sableux à loameux	Bas, Milieu
<i>Comarum palustris</i>	Comaret des marais	Marsh Cinquefoil	Indigène	3		35	25	Élevée à très élevée	Loam sableux	Bas
<i>Desmodium canadense</i>	Desmodie du Canada	Canadian Tick-Trefoil	Indigène	4		85	45	Moyenne	Loam argileux à argileux	Milieu
<i>Eupatorium maculatum</i>	Eupatoire maculée	Purple Joe-Pye Weed	Indigène	3		200	90	Moyenne à élevée	Loameux à loam argileux	Bas, Milieu
<i>Eupatorium perfoliatum</i>	Eupatoire perfoliée	Perfoliate Thoroughwort	Indigène	3		75	45	Moyenne à élevée	Tout type de sol	Bas
<i>Heliopsis helianthoides</i>	Héliopsis faux-hélianthe	False Sunflower	Indigène	3		120	90	Faible à moyenne	Sableux à loameux	Milieu, Replat
<i>Heliopsis helianthoides</i> 'Goldgefieder'	Héliopsis faux-hélianthe 'Goldgefieder'	'Goldgefieder' False Sunflower	Cultivar d'indigène	3		100	45	Faible à moyenne	Sableux à loameux	Milieu, Replat
<i>Heliopsis helianthoides</i> 'Midwest Dreams'	Héliopsis faux-hélianthe 'Midwest Dreams'	'Midwest Dreams' False Sunflower	Cultivar d'indigène	3		80-90	45	Faible à moyenne	Sableux à loameux	Milieu, Replat
<i>Iris versicolor</i>	Iris versicolore	Blue Flag Iris	Indigène	3		55	40	Élevée à très élevée	Tout type de sol	Bas, Milieu
<i>Iris versicolor</i> et cultivars	Iris versicolore	Blue Flag Iris	Cultivar d'indigène	3		60-80	40	Élevée à très élevée	Tout type de sol	Bas, Milieu
<i>Lathyrus maritimus</i>	Gesse maritime	Beach Pea	Indigène	3		25	60	Faible	Sableux	Milieu
<i>Ligusticum scoticum</i>	Livèche écossaise	Scotch Lovage	Indigène	0		55	60	Faible	Sableux, graveleux	Milieu

Tolérance aux sels au niveau du sol	Type d'enracinement	Rôle de la plante		Type de croissance	Faune		COMMENTAIRES
		Stabilisation	Écran solaire		Nourriture	Disponibilité en pépinière	
Non	Rhizome superficiel			Rapide		Moyenne	Préférence pour les sols fertiles. Tolère les zones constamment humides.
Non	Rhizome superficiel			Rapide		Moyenne	Préférence pour les sols bien drainés. Adapté pour les rivages argileux. Plante grimpante. Peut devenir envahissante.
Non	Abondant et profond			Moyenne		Moyenne	Adapté pour les rivages argileux.
Non	Rhizome			Moyenne		Moyenne	Plante aquatique. Préférence pour les sols acides et fertiles.
Non	Superficiel			Moyenne		Moyenne	Préférence pour les sols fertiles.
Non	Superficiel			Moyenne		Faible	Fleur jaune double. Plus compact que l'espèce. Syn.: <i>C. palustris</i> 'Multiplex'.
Non	Superficiel			Moyenne		Faible	Fleur jaune plus grande que l'espèce.
Non	Superficiel			Moyenne		Faible	Sélection compacte aux fleurs blanches. Toutes les parties de la plante sont considérées toxiques.
Non	Abondant et modérément profond			Rapide		Très bonne	Préférence pour les sols acides.
Non	Abondant et modérément profond			Moyenne		Moyenne	Préférence pour les sols fertiles. Couvre-sol. Tolère les sols détrempés. Syn.: <i>Potentilla palustris</i> .
Non	Abondant et modérément profond			Moyenne		Moyenne	Plante fixatrice d'azote.
Non	Abondant et modérément profond			Moyenne		Très bonne	Préférence pour les sols lourds, fertiles, calcaires et bien drainés.
Non	Abondant et modérément profond			Moyenne		Bonne	
Non	Abondant et modérément profond			Rapide		Très bonne	Résistante à la sécheresse.
Non	Abondant et modérément profond			Rapide		Faible	Fleur double, jaune orangé. Floraison prolongée.
Non	Abondant et modérément profond			Rapide		Faible	Fleur simple au ton de jaune et de orangé. Port très compact.
Modérée	Superficiel			Rapide		Excellente	Préférence pour les sols bien drainés. Plante ignorée des cerfs.
Modérée	Superficiel			Rapide		Excellente	Préférence pour les sols bien drainés. Plante ignorée des cerfs.
Oui	Abondant et modérément profond			Moyenne		Moyenne	Adapté aux conditions maritimes.
Oui	Abondant et modérément profond			Moyenne		Faible	Adapté aux conditions maritimes.

# Vivaces

Nom latin	Nom français	Nom anglais	Origine	Zone de rusticité	Exposition	Hauteur (centimètre)	Largeur (centimètre)	Humidité du sol	Type de sol	Localisation sur le talus
<i>Lobelia cardinalis</i>	Lobélie cardinale	Cardinal Flower	Indigène	3		90	30	Élevée à moyenne	Loam argileux à loameux	Bas
<i>Lobelia cardinalis</i> et cvs	Lobélie cardinale	Cardinal Flower	Cultivar d'indigène	3-5		90-120	30	Élevée à moyenne	Loam argileux à loameux	Bas
<i>Mentha arvensis</i>	Menthe du Canada	Wild Mint	Indigène	3		50	45	Élevée à moyenne	Tout type de sol	Bas, Milieu
<i>Mertensia maritima</i>	Mertensie maritime	Sea Bluebells	Indigène	2		15	40	Élevée	Loam sableux	Bas, Milieu
<i>Myosotis laxa</i>	Myosotis laxiflore	Small Forget-Me-Not	Indigène	3		30	35	Élevée	Tout type de sol	Bas, Milieu
<i>Petasites frigidus</i> var. <i>palmatus</i>	Pétasite palmé	Northern Sweet Coltsfoot	Indigène	2		40	30	Moyenne à élevée	Tout type de sol	Bas
<i>Physostegia virginiana</i>	Physostégie de Virginie	Obedient Plant	Indigène	3		70	40	Moyenne à élevée	Tout type de sol	Bas, Milieu
<i>Pontederia cordata</i>	Pontédérie cordée	Pickernelweed	Indigène	2		60-80	40-60	Élevée	Loameux à loam argileux	Bas
<i>Pontederia cordata</i> 'White Pike'	Pontédérie cordée 'White Pike'	'White Pike' Pickernelweed	Cultivar d'indigène	3		60	40-60	Élevée	Loameux à loam argileux	Bas
<i>Rudbeckia laciniata</i>	Rudbeckie laciniée	Cut-Leaved Coneflower	Indigène	3		150	60	Moyenne à élevée	Tout type de sol	Milieu, Replat
<i>Rudbeckia laciniata</i> 'Goldquelle'	Rudbeckie laciniée 'Goldquelle'	'Goldquelle' Cut-Leaved Coneflower	Cultivar d'indigène	3		90	60	Moyenne à élevée	Tout type de sol	Milieu, Replat
<i>Sagittaria latifolia</i>	Sagittaire latifoliée	Broadleaf Arrowhead	Indigène	3		100	50	Très élevée	Argileux	Bas
<i>Sanguisorba canadensis</i>	Sanguisorbe du Canada	Canadian Burnet	Indigène	3		90	70	Faible à moyenne	Tout type de sol	Milieu, Replat
<i>Scutellaria lateriflora</i>	Scutélaire latériflore	Side-Flowering Skullcap or Mad Dog Skullcap	Indigène	3		70	30	Élevée à moyenne	Loameux	Milieu, Replat
<i>Solidago canadensis</i>	Verge d'or du Canada	Canada Goldenrod	Indigène	2		110	40	Faible à moyenne	Tout type de sol	Milieu, Replat
<i>Solidago</i> x 'Golden Baby' ou 'Baby Gold'	Verge d'or du Canada 'Golden Baby'	'Golden Baby' Dwarf Goldenrod	Cultivar d'indigène	3		60-70	45-60	Faible à moyenne	Tout type de sol	Milieu, Replat
<i>Solidago</i> x 'Laurin'	Verge d'or du Canada 'Laurin'	'Laurin' Dwarf Goldenrod	Cultivar d'indigène	3		30-40	45-60	Faible à moyenne	Tout type de sol	Milieu, Replat
<i>Solidago</i> x 'Strahlenkrone'	Verge d'or du Canada 'Crown of Rays'	'Crown of Rays' Goldenrod	Cultivar d'indigène	3		60-100	45-60	Faible à moyenne	Tout type de sol	Milieu, Replat
<i>Solidago</i> x 'Sweety'	Verge d'or du Canada 'Sweety'	'Sweety' Dwarf Goldenrod	Cultivar d'indigène	4		30	45-60	Faible à moyenne	Tout type de sol	Milieu, Replat
<i>Symphotrichum lateriflorum</i>	Aster latériflore	Calico Aster	Indigène	3		70	45	Moyenne	Tout type de sol	Milieu, Replat
<i>Symphotrichum lateriflorum</i> 'Lady in Black'	Aster latériflore 'Lady in Black'	'Lady in Black' Calico Aster	Cultivar d'indigène	5		70	50	Moyenne	Tout type de sol	Milieu, Replat

Tolérance aux sels au niveau du sol	Type d'enracinement	Rôle de la plante		Type de croissance	Faune		Disponibilité en pépinière	COMMENTAIRES
		Stabilisation	Écran solaire		Nourriture			
Non	Abondant et modérément profond	☼☼	☼☼	Moyenne	🐌		Excellente	Préférence pour les sols fertiles. Plante de rivage en eau calme. Résistante aux limaces. Se ressème.
Non	Abondant et modérément profond	☼☼	☼☼	Moyenne	🐌		Moyenne	Préférence pour les sols fertiles. Plante de rivage en eau calme.
Non	Abondant et modérément profond	☼☼		Rapide			Bonne	Planter en isolé. Plante envahissante. Syn.: <i>M. canadensis</i> .
Oui	Superficiel	☼☼		Moyenne			Faible	Préférence pour les sols fertiles. Feuillage persistant. Adapté aux conditions maritimes.
Non	Abondant et modérément profond	☼☼		Rapide			Bonne	Préférence pour les sols fertiles. Syn.: <i>M. palustris</i> .
	Profond	☼☼		Rapide			Faible	Préfère les sols frais. Peut devenir envahissante dans un sol riche et humide.
Non	Abondant et modérément profond	☼☼		Rapide	🐌		Bonne	Préférence pour les sols bien drainés.
Non	Rhizome			Moyenne	🐌		Moyenne	Plante aquatique. Préférence pour les sols fertiles. Plante de rivage en eau calme.
Non	Rhizome			Moyenne			Moyenne	Fleur blanche.
Non	Abondant et profond	☼☼	☼☼	Rapide	🐌		Bonne	Résistante aux limaces. Plante ignorée des cerfs. Éviter <i>R. hirta</i> .
Non	Abondant et profond	☼☼	☼☼	Rapide	🐌		Bonne	Sélection au port compact et aux tiges solides.
	Tubercule superficiel			Moyenne	🐌		Moyenne	Préférence pour les sols fertiles et détrempés. Plante de rivage en eau calme. Tolère la pollution de l'eau. Efficace pour absorber le phosphate.
Oui	Abondant et modérément profond	☼☼		Moyenne			Moyenne	Adapté pour les conditions maritimes.
Non	Abondant et modérément profond	☼☼		Rapide	🐌		Moyenne	Préférence pour les sols alcalins.
Oui	Abondant et profond	☼☼	☼☼	Rapide	🐌		Très bonne	Mellifère.
Oui	Abondant et profond	☼☼	☼☼	Rapide			Bonne	Large floraison jaune or. Ne requiert pas de support.
Oui	Abondant et profond	☼☼	☼☼	Rapide			Faible	Port très compact et arrondi. Floraison tardive, jaune vif. Vigoureux.
Oui	Abondant et profond	☼☼	☼☼	Rapide			Faible	Large inflorescence jaune brillant. Tiges solides. Ne requiert pas de support.
Oui	Abondant et profond	☼☼	☼☼	Rapide			Faible	Port très compact et arrondi. Floraison jaune citron.
Non	Superficiel		☼☼	Moyenne	🐌		Bonne	Préférence pour les sols bien drainés. Syn.: <i>Aster lateriflorus</i> .
Non	Superficiel		☼☼	Moyenne			Bonne	Port plus compact que l'espèce. Feuillage pourpre foncé. Syn.: <i>Aster lateriflorus</i> 'Lady in Black'.

# Vivaces

Nom latin	Nom français	Nom anglais	Origine	Zone de rusticité	Exposition	Hauteur (centimètre)	Largeur (centimètre)	Humidité du sol	Type de sol	Localisation sur le talus
<i>Symphotrichum lateriflorum</i> 'Prince'	Aster latéiflore 'Prince'	'Prince' Calico Aster	Cultivar d'indigène	4		50-60	45-60	Moyenne	Tout type de sol	Milieu, Replat
<b><i>Symphotrichum novae-angliae</i></b>	Aster de Nouvelle-Angleterre	New England Aster	Indigène	3		50	40	Faible à moyenne	Tout type de sol	Replat
<i>Symphotrichum novae-angliae</i> 'Harrington's Pink'	Aster de Nouvelle-Angleterre 'Harrington's Pink'	'Harrington's Pink' New England Aster	Cultivar d'indigène	3		110	60	Faible à moyenne	Tout type de sol	Replat
<i>Symphotrichum novae-angliae</i> 'Purple Dome'	Aster de Nouvelle-Angleterre 'Purple Dome'	'Purple Dome' New England Aster	Cultivar d'indigène	3		50	40	Faible à moyenne	Tout type de sol	Replat
<i>Symphotrichum novae-angliae</i> 'Red Star'	Aster de Nouvelle-Angleterre 'Red Star'	'Red Star' New England Aster	Cultivar d'indigène	3		40	40	Faible à moyenne	Tout type de sol	Replat
<i>Symphotrichum novae-angliae</i> 'Rudelsburg'	Aster de Nouvelle-Angleterre 'Rudelsburg'	'Rudelsburg' New England Aster	Cultivar d'indigène	3		100-110	60	Faible à moyenne	Tout type de sol	Replat
<i>Symphotrichum novae-angliae</i> 'Vibrant Dome'	Aster de Nouvelle-Angleterre 'Vibrant Dome'	'Vibrant Dome' New England Aster	Cultivar d'indigène	3		45	30	Faible à moyenne	Tout type de sol	Replat
<i>Symphotrichum novi-belgii</i>	Aster de la Nouvelle-Belgique	New Belgium Aster	Indigène	3		90	45	Faible	Tout type de sol	Bas, Milieu
<i>Symphotrichum novi-belgii</i> et cultivars	Aster de la Nouvelle-Belgique	New Belgium Aster	Cultivar d'indigène	3		40-110	30-50	Faible	Tout type de sol	Bas, Milieu, Replat
<b><i>Thalictrum venulosum</i></b>	Pigamon veiné	Veiny Meadow-Rue	Indigène	3		40-60	25	Moyenne à élevée	Sableux à loameux	Milieu, Replat
<b><i>Verbena hastata</i></b>	Verveine hastée	Blue Vervain	Indigène	3		110	45	Élevée	Tout type de sol	Bas, Milieu

# Fougères

<b><i>Athyrium filix-femina</i></b>	Athyrie fougère-femelle	Lady Fern	Indigène	3		60	20	Faible à élevée	Sableux à loameux	Milieu, Replat
<i>Athyrium filix-femina</i> 'Nanum'	Athyrie fougère-femelle 'Nanum'	'Nanum' Northern Lady Fern	Cultivar d'indigène	3		25	25	Faible à élevée	Sableux à loameux	Milieu, Replat
<i>Athyrium filix-femina</i> 'Plumosum Axminster'	Athyrie fougère-femelle 'Plumosum Axminster'	Golden Plumose Lady Fern	Cultivar d'indigène	4		75-80	60-75	Faible à élevée	Sableux à loameux	Milieu, Replat
<b><i>Athyrium filix-femina</i> var. <i>angustum</i></b>	Fougère-femelle du Nord	Northern Lady Fern	Indigène	3		60	60	Faible à élevée	Sableux à loameux	Milieu, Replat
<i>Athyrium filix-femina</i> 'Veronica-cristatum'	Athyrie fougère-femelle 'Veronica-cristatum'	Miss Vernon's Crested Lady Fern	Cultivar d'indigène	3		55-60	45-60	Faible à élevée	Sableux à loameux	Milieu, Replat
<b><i>Athyrium thelypteroides</i></b>	Athyrium fausse-thélyptéride	Silvery Glade-Fern	Indigène	4		60-100	50	Élevée à moyenne	Loameux à loam argileux	Milieu, Replat
<b><i>Dryopteris cristata</i></b>	Dryoptère à crêtes	Crested Wood-fern	Indigène	3		55	30	Moyenne	Loameux	Bas, Milieu
<b><i>Dryopteris marginalis</i></b>	Dryoptère à sores marginaux	Marginal Wood-fern	Indigène	3		60	60	Moyenne à faible	Tout type de sol	Replat
<b><i>Onoclea sensibilis</i></b>	Onoclée sensible	Sensitive Fern	Indigène	2		80	45	Élevée	Tout type de sol	Bas, Milieu
<b><i>Osmunda cinnamomea</i></b>	Osmonde cannelle	Cinnamon Fern	Indigène	2-3		60-150	60	Élevée à moyenne	Loam argileux à loam sableux	Bas, Milieu
<b><i>Osmunda regalis</i></b>	Osmonde royale	Royal Fern	Indigène	2		125	150	Élevée	Sableux à loam argileux	Bas, Milieu
<b><i>Thelypteris palustris</i></b>	Thélyptère des marais	Marsh Shield-Fern	Indigène	3		60	60	Élevée	Tout type de sol	Bas, Milieu



































Tolérance aux sels au niveau du sol	Type d'enracinement	Rôle de la plante		Type de croissance	Faune		Disponibilité en pépinière	COMMENTAIRES
		Stabilisation	Écran solaire		Nourriture			
Non	Superficiel			Moyenne			Bonne	Bonne tolérance à l'oïdium. Port beaucoup plus compact que l'espèce. Feuillage pourpre et fleur blanche à cœur rouge. Ne requiert pas de tuteurage. Syn.: <i>Aster lateriflorus</i> 'Prince'.
Modérée	Abondant et modérément profond			Rapide			Très bonne	Préférence pour les sols bien drainés. Syn.: <i>Aster novae-angliae</i> .
Modérée	Abondant et modérément profond			Rapide			Moyenne	Fleur rose saumoné plus tardive que les autres. Syn.: <i>Aster novae-angliae</i> 'Harrington's Pink'.
Modérée	Abondant et modérément profond			Rapide			Moyenne	Solide sélection au port compact et arrondi. Ne requiert pas de tuteurage. Fleur mauve. Syn.: <i>Aster novae-angliae</i> 'Purple Dome'.
Modérée	Abondant et modérément profond			Rapide			Faible	Port compact. Fleur rouge. Syn.: <i>Aster novae-angliae</i> 'Red Star'.
Modérée	Abondant et modérément profond			Rapide			Faible	Fleur rouge vif. Facile de culture. Syn.: <i>Aster novae-angliae</i> 'Rudelsburg'.
Modérée	Abondant et modérément profond			Rapide			Faible	Fleur rose. Syn.: <i>Aster novae-angliae</i> 'Vibrant Dome'.
Modérée	Profond			Rapide			Bonne	Préférence pour les sols bien drainés. Syn.: <i>Aster novi-belgii</i> .
Modérée	Profond			Rapide			Bonne	Préférence pour les sols bien drainés. Syn.: <i>Aster novi-belgii</i> et cultivars.
	Superficiel			Moyenne			Faible à moyenne	Syn.: <i>T. confine</i> .
Non	Abondant et profond			Rapide			Très bonne	Bisannuelle.

Non	Superficiel			Moyenne			Bonne	Préférence pour les sols fertiles et frais. Plante ignorée des cerfs.
Non	Superficiel			Moyenne			Faible à Moyenne	Feuillage vert foncé et dense. Tolère le soleil en autant que le sol est humide.
Non	Superficiel			Moyenne			Moyenne	Préférence pour les sols fertiles et frais. Feuillage vert pomme brillant. Tolère le soleil en autant que le sol est humide.
Non	Superficiel			Moyenne			Faible à Moyenne	Colori spectaculaire. Tolère le soleil en autant que le sol est humide.
Non	Superficiel			Moyenne			Moyenne	Préférence pour les sols fertiles et frais. Feuillage vert duveteux. Protéger des vents.
Non	Superficiel			Moyenne			Moyenne	Préférence pour les sols acides et fertiles.
Non	Superficiel			Moyenne			Moyenne	Préférence pour les sols acides et tourbeux.
Non	Superficiel			Rapide			Moyenne	Préférence pour les sols fertiles. Plante ignorée des cerfs. Feuillage persistant.
Non	Superficiel			Rapide			Moyenne	Préférence pour les sols acides, fertiles et bien drainés. Tolère les sols détrempés. Associée dans la nature avec les aulnes et les saules.
	Profond			Rapide			Très bonne	Préférence pour les sols acides. Tolère les sols détrempés. Plante ignorée des cerfs. Adapté pour les conditions maritimes.
Non	Rhizome superficiel			Moyenne			Faible	Préférence pour les sols tourbeux, acides, fertiles, profonds et bien drainés. Tolère les sols détrempés.
Non	Superficiel			Moyenne			Faible	Préférence pour les sols acides. Syn.: <i>Dryopteris thelypteris</i> .



# Graminées et plantes apparentées

Nom latin	Nom français	Nom anglais	Origine	Zone de rusticité	Exposition	Hauteur (centimètre)	Largeur (centimètre)	Humidité du sol	Type de sol	Localisation sur le talus
<i>Acorus calamus</i>	Acore roseau	Sweet Flag	Naturalisée	3		60-100	60	Élevée	Tout type de sol	Bas
<i>Acorus calamus</i> 'Variegatus'	Acore roseau	Variegated Sweet Flag	Cultivar de naturalisée	4		60-80	60	Élevée	Tout type de sol	Bas
<i>Andropogon gerardii</i>	Barbon de Gérard	Big Bluestem	Indigène	4		150-200	60-75	Moyenne à élevée	Tout type de sol	Bas, Replat
<i>Bolboschoenus fluviatilis</i>	Scirpe fluviale	River Bulrush	Indigène	3		100-200	50	Élevée	Loameux à loam argileux	Bas
<i>Calamagrostis canadensis</i>	Calamagrostide du Canada	Bluejoint	Indigène	3		130	60	Élevée à moyenne	Tout type de sol	Bas, Milieu
<i>Deschampsia cespitosa</i>	Deschampsie cespiteuse	Tufted Hairgrass	Indigène	3		85-100	45-60	Moyenne	Tout type de sol	Milieu, Replat
<i>Dichanthelium clandestinum</i>	Panic clandestin	Deer Tongue Grass	Indigène	4		70-120	40	Faible à moyenne	Loameux, graveleux	Milieu, Replat
<i>Elymus canadensis</i>	Élyme du Canada	Canada Wild Rye	Indigène	3		30-100	40	Moyenne	Tout type de sol	Milieu, Replat
<i>Glyceria canadensis</i>	Glycérie du Canada	Canada Mannagrass	Indigène	3		30-100	20-25	Moyenne à élevée	Tout type de sol	Bas
<i>Glyceria grandis</i>	Glycérie géante	Tall Mannagrass	Indigène	3		100-160	20-25	Moyenne à élevée	Tout type de sol	Bas
<i>Glyceria striata</i>	Glycérie striée	Nerved Mannagrass	Indigène	3		30-90	20-25	Moyenne à élevée	Tout type de sol	Bas
<i>Juncus effusus</i>	Jonc épars	Common Rush	Indigène	3		60	60	Élevée	Tout type de sol	Bas
<i>Schizachyrium scoparium</i>	Schizachyrium à balais	Little Bluestem	Indigène	4		75	30-40	Faible	Tout type de sol	Milieu, Replat
<i>Schizachyrium scoparium</i> 'Prairie Blues'	Schizachyrium à balais 'Prairie Blues'	'Prairie Blues' Little Blue Stem	Cultivar d'indigène	4		100	60	Faible	Tout type de sol	Milieu, Replat
<i>Schizachyrium scoparium</i> 'The Blues'	Schizachyrium à balais 'The Blues'	'The Blues' Little Blue Stem	Cultivar d'indigène	4		45-60	45-60	Faible	Tout type de sol	Milieu, Replat
<i>Schoenoplectus acutus</i> var. <i>acutus</i>	Scirpe aigu	Hardstem Bulrush	Indigène	2		50-200	45	Élevée	Loameux à loam argileux	Bas
<i>Schoenoplectus pungens</i>	Scirpe d'Amérique	American Bulrush	Indigène	1		20-100	50	Élevée	Loameux à loam argileux	Bas
<i>Schoenoplectus tabernaemontani</i>	Scirpe des étangs	Softstem Bulrush	Indigène	2		50-250	50	Élevée	Loameux à loam argileux	Bas
<i>Scirpus cyperinus</i>	Scirpe Souchet	Common Wool-Grass	Indigène	3		100-150	50	Élevée	Loameux à loam argileux	Bas
<i>Sorghastrum nutans</i>	Faux-sorgho penché	Indian Grass	Indigène	4		150-175	40	Moyenne	Tout type de sol	Bas, Milieu
<i>Spartina pectinata</i>	Spartine pectinée	Prairie Cordgrass	Indigène	3		150	100	Élevée à moyenne	Tout type de sol	Bas, Milieu

Tolérance aux sels au niveau du sol	Type d'enracinement	Rôle de la plante		Type de croissance	Faune		Disponibilité en pépinière	COMMENTAIRES
		Stabilisation	Écran solaire		Nourriture			
	Rhizome superficiel			Moyenne			Moyenne	Tolère 20 cm d'eau par-dessus le collet. Syn: Belle angélique. S'étale beaucoup.
	Rhizome superficiel			Moyenne			Bonne	Feuillage panaché blanc crème. Tolère l'ombre.
Moderée	Abondant et profond			Rapide			Bonne	Préférence pour les sols bien drainés. Résistante à la sécheresse.
Non	Rhizome volumineux			Moyenne			Moyenne	Tolère les sols détrempés ou inondés de façon temporaire. Syn.: <i>Scirpus fluviatilis</i> .
Non	Abondant et profond			Moyenne			Bonne	Préférence pour les sols détrempés ou inondés de façon saisonnière ou temporaire.
Non	Superficiel			Rapide			Bonne	Préférence pour les sols fertiles et bien drainés. Ne tolère pas la sécheresse. Peut s'ensemencer.
Oui	Abondant et superficiel			Rapide			Moyenne	Préférence pour les sols fertile et humide et peut tolérer l'ombre. Syn.: <i>Panicum clandestinum</i> .
Moderée	Abondant et profond			Rapide			Bonne	Adapté aux conditions maritimes.
	Rhizome superficiel			Rapide			Moyenne	Préférence pour les sols détrempés ou inondés de façon saisonnière ou temporaire.
	Rhizome superficiel			Rapide			Moyenne	Préférence pour les sols détrempés ou inondés de façon saisonnière ou temporaire.
	Rhizome superficiel			Rapide			Moyenne	Préférence pour les sols détrempés ou inondés de façon saisonnière ou temporaire.
Moderée	Abondant et superficiel			Rapide			Bonne	Tolère les sols détrempés ou inondés de façon temporaire. Feuillage persistant.
Non	Abondant et profond			Moyenne			Bonne	Préférence pour les sols bien drainés. Syn.: <i>Andropogon scoparium</i> .
Non	Abondant et profond			Moyenne				Feuillage gris bleuté, inflorescence argenté. Tolère la sécheresse.
Non	Abondant et profond			Moyenne				Préférence pour les sols bien drainés. Feuillage bleuté.
Non	Rhizome robuste			Moyenne				Supporte les fluctuations du niveau de l'eau jusqu'à une profondeur de 30 cm. Syn.: <i>Scirpus acutus</i> .
Non	Rhizome traçant			Moyenne			Moyenne	Tolère les sols détrempés ou inondés de façon temporaire. Syn.: <i>Scirpus americanus</i> .
Non	Rhizome robuste			Moyenne			Moyenne	Tolère les sols détrempés ou inondés de façon temporaire. Syn.: <i>Scirpus validus</i> ou <i>Scirpus lacustris</i> .
Non	Rhizome volumineux			Moyenne			Moyenne	Tolère les sols détrempés ou inondés de façon temporaire.
Non	Abondant et profond			Moyenne			Bonne	Préférence pour les sols frais et bien drainés. Espèce souvent dominante.
Oui	Abondant et profond			Rapide			Bonne	Adapté aux conditions maritimes. Espèce souvent dominante.

# Comités

## Orientation et contenu

### Comité directeur

- Guy **Boulet**, AQPP
- Émilie **Brassard-D'Astous**, agente de liaison FHOQ – AQPP
- Mario **Comtois**, B. Sc. Biol., agr., IQDHO
- Luce **Daigneault**, agr., directrice générale FHOQ
- Isabelle **Dupras**, AQPP
- André **Gosselin**, AQPP
- Nicolas **Hamelin**, ROBVG
- Louise **Laramée**, AQPP
- Claire **Michaud**, MDDEP
- Brigitte **Mongeau**, dta, IQDHO
- Sophie **Rochefort**, Ph.D., agr., FHOQ

### Comité de travail

- Luc **Bourdon**, APGQ
- Fay **Cotton**, MRNF
- Jean-Luc **Daiwally**, AQPP
- Suzanne **Desrochers**, AQPP
- Mélanie **Glorieux**, AAPQ
- Josée **Gosselin**, ASHOQ
- Pierre **Guilbeault**, APGQ
- Jean-Maurice **Hamel**, MAPAQ
- Marc **Légaré**, dta, IQDHO
- Jean-François **Meister**, AQPP
- Martin **Mergl**, APPQ
- Mario **Morin**, AQPP
- Carole **Roberge**, AQPP
- Jean-Pierre **Roberge**, AQPP
- Line **Roberge**, ASHOQ
- David **Rodier**, APPQ
- Isabelle **Simard**, MDDEP
- Pierre **Villeneuve**, AJQ

### Comité réviseur

#### Liste des plantes ligneuses :

- Nathalie **Bédard**, B.A.P., M.A., RAPPEL
- Myriam **Lafrenière-Landry**, B.Sc.A., ACIA
- Marc **Légaré**, dta, IQDHO
- Benoît **Limoges**, biologiste, MDDEP
- Brigitte **Mongeau**, dta, IQDHO
- Romain **Néron**, agr., MAPAQ
- Isabelle **Simard**, biologiste M. Sc., MDDEP

#### Liste des plantes herbacées (vivaces) :

- Mario **Comtois**, B. Sc. Biol., agr., IQDHO
- Frédéric **Coursol**, B. Sc. Biol., botaniste consultant
- Myriam **Lafrenière-Landry**, B.Sc.A., ACIA
- Brigitte **Mongeau**, dta, IQDHO
- Fred **Oehmichen**, B.A.P., M.A.P., Pépinière Oka Fleurs
- Annie **Simard**, biologiste M. Sc., MDDEP
- Isabelle **Simard**, biologiste M. Sc., MDDEP

**AAPO**  
**ACIA**  
**AJQ**  
**APGQ**  
**APPQ**  
**AQPP**  
**ASHOQ**  
**FIHOQ**  
**IQDHO**  
**MAPAQ**  
**MDDEP**  
**MRNF**  
**RAPPEL**  
  
**ROBVG**

Ce répertoire a été rendu possible grâce à la contribution financière du ministère de l'Agriculture, des Pêcheries et de l'Alimentation du Québec (MAPAQ), dans le cadre du (*Programme d'appui financier aux associations de producteurs désignées*).

La production de ce répertoire a été rendue possible grâce aussi à des investissements du ministère du Développement durable, de l'Environnement et des Parcs (MDDEP), du Regroupement des organisations de bassin versant du Québec (ROBVG), de la FHOQ, de l'AQPP et de l'ensemble de l'industrie de l'horticulture ornementale.



FÉDÉRATION INTERDISCIPLINAIRE  
DE L'HORTICULTURE  
ORNEMENTALE  
DU QUÉBEC

[www.fihoq.qc.ca](http://www.fihoq.qc.ca)  
[fihoq@fihoq.qc.ca](mailto:fihoq@fihoq.qc.ca)

3230, rue Sicotte, Local E-300 Ouest  
Saint-Hyacinthe, Québec  
J2S 7B3

Québec

• Ministère de l'Agriculture, des Pêcheries et de l'Alimentation  
• Ministère du Développement Durable, de l'Environnement et des Parcs

[www.mapaq.gouv.qc.ca](http://www.mapaq.gouv.qc.ca)  
[info@mapaq.gouv.qc.ca](mailto:info@mapaq.gouv.qc.ca)  
[www.mddep.gouv.qc.ca](http://www.mddep.gouv.qc.ca)  
[info@mddep.gouv.qc.ca](mailto:info@mddep.gouv.qc.ca)



[www.aqpp.org](http://www.aqpp.org)  
[aqpp@fihoq.qc.ca](mailto:aqpp@fihoq.qc.ca)

Association des architectes paysagistes du Québec  
Agence canadienne d'inspection des aliments  
Association des jardineries du Québec  
Association des producteurs de gazon du Québec  
Association des paysagistes professionnels du Québec  
Association québécoise des producteurs en pépinière  
Association des services en horticulture ornementale du Québec  
Fédération interdisciplinaire de l'horticulture ornementale du Québec  
Institut québécois du développement de l'horticulture ornementale  
Ministère de l'Agriculture, des Pêcheries et de l'Alimentation du Québec  
Ministère du Développement durable, de l'Environnement et des Parcs  
Ministère des Ressources naturelles et de la Faune  
Regroupement des associations pour la protection de l'environnement des lacs et cours d'eau de l'Estrie et du haut bassin de la rivière Saint-François  
Regroupement des organisations de bassin versant du Québec

# Une image de marque

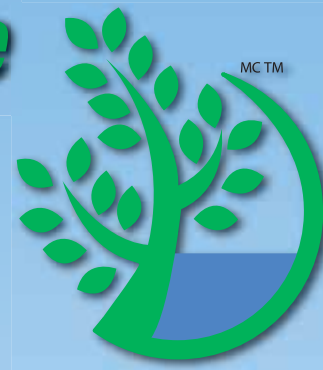

La FIHOQ a conçu pour vous une *image de marque* pour promouvoir les végétaux recommandés pour la végétalisation des bandes riveraines auprès de vos clients.

Pour obtenir des renseignements supplémentaires ou pour vous procurer le matériel promotionnel, communiquez avec la FIHOQ au 450-774-2228.

Le pictogramme ne pourra être utilisé que pour identifier les végétaux recommandés dans le répertoire et son utilisation devra être autorisée par la Fédération.

Le matériel comprend les éléments suivants :

- Pictogramme d'identification des végétaux recommandés
- Dépliant de sensibilisation
- Affiche incitative
- Affichette pour le lieu de vente
- Étiquettes
- Ruban de table



Ce répertoire a été rendu possible grâce à la contribution financière du ministère de l'Agriculture, des Pêcheries et de l'Alimentation du Québec (MAPAQ), par l'intermédiaire du (Programme d'appui financier aux associations de producteurs désignées).

Il a également pu être réalisé grâce à des investissements importants :

- de la Fédération interdisciplinaire de l'horticulture ornementale du Québec (FIHOQ)
- du ministère du Développement durable, de l'Environnement et des Parcs (MDDEP)
- de l'Association québécoise des producteurs en pépinière (AQPP)
- du Regroupement des organisations de bassin versant du Québec (ROBVQ)

Vous pouvez vous procurer ce répertoire (en format PDF) ou questionner le moteur de recherche, en consultant le site de la FIHOQ et celui de l'AQPP aux adresses suivantes :



[www.fihoq.qc.ca](http://www.fihoq.qc.ca)  
[fihoq@fihoq.qc.ca](mailto:fihoq@fihoq.qc.ca)

[www.fihoq.qc.ca](http://www.fihoq.qc.ca)  
[www.aqpp.org](http://www.aqpp.org)



[www.aqpp.org](http://www.aqpp.org)  
[aqpp@fihoq.qc.ca](mailto:aqpp@fihoq.qc.ca)



[www.robvq.qc.ca](http://www.robvq.qc.ca)  
[info@robvq.qc.ca](mailto:info@robvq.qc.ca)



Québec 

• Ministère de l'Agriculture, des Pêcheries et de l'Alimentation  
• Ministère du Développement Durable, de l'Environnement et des Parcs

[www.mapaq.gouv.qc.ca](http://www.mapaq.gouv.qc.ca)  
[info@mapaq.gouv.qc.ca](mailto:info@mapaq.gouv.qc.ca)  
[www.mddep.gouv.qc.ca](http://www.mddep.gouv.qc.ca)  
[info@mddep.gouv.qc.ca](mailto:info@mddep.gouv.qc.ca)

## Appendix B: Invasive Plant Species

---

Phragmites – Extremely invasive, found in wet to very wet areas, along creeks and in ditches.



Flowering rush – Found mainly in wet areas, wetlands, creek banks, shorelines, ditches.



Garlic mustard – Found in wet to dry habitats.



Purple Loosestrife – Found in wetlands, shorelines, creek banks, meadows.



Giant hogweed - Not yet identified here but may be found in dry and wet areas – Poisonous



Japanese knotweed – Found in wet to dry habitats.



## **Appendix C: Suppliers of Mitigation Products**

---

### Texel Geocel

Quebec City, QC

Tel: (418) 658-0200

Toll Free: 1-800-463-0088

Fax: (418) 658-0477

Email: [info@texelgeosol.com](mailto:info@texelgeosol.com)

Website: [www.texelgeosol.com](http://www.texelgeosol.com)

Products: Geotextiles

### Transfer Depot

Seaway Road

(514) 249-0961

Products: Wood chips for mulch to stabilize soil

### Geosynthetic Systems

Ottawa, ON

Tel: (613) 733-9585

Toll Free: 1-866-490-4436

Fax: (613) 733-3795

Email: [gepros@geosyntheticssystem.com](mailto:gepros@geosyntheticssystem.com)

Website: [www.geosyntheticssystem.com](http://www.geosyntheticssystem.com)

Products: Erosion control blankets and mats, silt fences, geotextiles

### Environnement Rive-Nord

Pointe-aux-Trembles, QC

Tel: (450) 430-8666

Toll Free: 1-866-430-8666

Fax: (514) 642-2141

Email: [info@env-rivenord.com](mailto:info@env-rivenord.com)

Website: <http://env-rivenord.com/index1.html>

Products: Spill kits



## Appendix D: Important Contact Numbers

---

<b>Location</b>	<b>Telephone Number</b>
Kahnawà:ke Environment Protection	450-635-0600
Kahnawà:ke Transfer Depot	514-249-0961
Landfill Department	450-632-8774 514-943-2191
Lands Unit and Tioweró:ton Coordinator	450-638-8244
Tioweró:ton Caretakers	819-321-3375 Main 819-424-2377 North
Community Protection and Conservation Department	450-632-0635
Kahnawà:ke Peacekeepers	450-632-6505
Environment Canada's Emergency Hotline	514-283-2333

## **Appendix E: Landfill Policy and Procedures for Clean Soil (2013)**

---